

**ASME B18.3-2012**  
[Revision of ASME B18.3-2003 (R2008)]

# Socket Cap, Shoulder, Set Screws, and Hex Keys (Inch Series)

**AN AMERICAN NATIONAL STANDARD**



**The American Society of  
Mechanical Engineers**

FINESZ 泛微

INTENTIONALLY LEFT BLANK

**ASME B18.3-2012**

**[Revision of ASME B18.3-2003 (R2008)]**

# **Socket Cap, Shoulder, Set Screws, and Hex Keys (Inch Series)**

---

**AN AMERICAN NATIONAL STANDARD**



**The American Society of  
Mechanical Engineers**

**Two Park Avenue • New York, NY • 10016 USA**

Date of Issuance: April 24, 2013

This Standard will be revised when the Society approves the issuance of a new edition.

ASME issues written replies to inquiries concerning interpretations of technical aspects of this Standard. Periodically certain actions of the ASME B18 Committee may be published as Cases. Cases and interpretations are published on the ASME Web site under the Committee Pages at <http://cstools.asme.org/> as they are issued.

Errata to codes and standards may be posted on the ASME Web site under the Committee Pages to provide corrections to incorrectly published items, or to correct typographical or grammatical errors in codes and standards. Such errata shall be used on the date posted.

The Committee Pages can be found at <http://cstools.asme.org/>. There is an option available to automatically receive an e-mail notification when errata are posted to a particular code or standard. This option can be found on the appropriate Committee Page after selecting “Errata” in the “Publication Information” section.

ASME is the registered trademark of The American Society of Mechanical Engineers.

This code or standard was developed under procedures accredited as meeting the criteria for American National Standards. The Standards Committee that approved the code or standard was balanced to assure that individuals from competent and concerned interests have had an opportunity to participate. The proposed code or standard was made available for public review and comment that provides an opportunity for additional public input from industry, academia, regulatory agencies, and the public-at-large.

ASME does not “approve,” “rate,” or “endorse” any item, construction, proprietary device, or activity.

ASME does not take any position with respect to the validity of any patent rights asserted in connection with any items mentioned in this document, and does not undertake to insure anyone utilizing a standard against liability for infringement of any applicable letters patent, nor assumes any such liability. Users of a code or standard are expressly advised that determination of the validity of any such patent rights, and the risk of infringement of such rights, is entirely their own responsibility.

Participation by federal agency representative(s) or person(s) affiliated with industry is not to be interpreted as government or industry endorsement of this code or standard.

ASME accepts responsibility for only those interpretations of this document issued in accordance with the established ASME procedures and policies, which precludes the issuance of interpretations by individuals.

No part of this document may be reproduced in any form,  
in an electronic retrieval system or otherwise,  
without the prior written permission of the publisher.

The American Society of Mechanical Engineers  
Two Park Avenue, New York, NY 10016-5990

Copyright © 2013 by  
THE AMERICAN SOCIETY OF MECHANICAL ENGINEERS  
All rights reserved  
Printed in U.S.A.

# CONTENTS

Foreword .....	iv
Committee Roster .....	vi
Correspondence With the B18 Committee .....	vii
<b>1 Introductory Notes .....</b>	<b>1</b>
<b>2 General Data .....</b>	<b>2</b>
<b>Figure</b>	
1 Cup Point Variations .....	37
<b>Tables</b>	
1 Dimensions of Hexagon Socket Head Cap Screws .....	3
2 Dimensions of Under Head Fillets for Socket Head Cap Screws Threaded to the Head .....	6
3 Dimensions of Under Head Fillets for Socket Head Cap Screws With an Unthreaded Length of Body Diameter .....	7
4 Body and Grip Lengths for Socket Head Cap Screws .....	8
5 Lengths Beyond Sizes in Table 4 .....	12
6 Shank Straightness for Socket Head Cap Screws .....	13
7 Dimensions of Drilled Hexagon Socket Head Cap Screws .....	14
8 Dimensions of Hexagon Socket Flat Countersunk Head Cap Screws .....	16
9 Body and Grip Lengths for Socket Flat Countersunk Head Cap Screws .....	19
10 Lengths Beyond Sizes in Table 9 .....	22
11 Dimensions of Hexagon Socket Button Head Cap Screws .....	23
12 Dimensions of Low Head Hexagon Socket Cap Screws .....	26
13 Dimensions of Hexagon Socket Head Shoulder Screws .....	28
14 Dimensions of Hexagon Socket Set Screws .....	31
15 Hexagon Key Engagements for Short Length Set Screws .....	35
16 Dimensions of Optional Cup Points .....	36
17 Dimensions of Hexagon Keys and Bits .....	38
18 Dimensions of Hexagon Sockets .....	40
<b>Mandatory Appendices</b>	
I Gages and Gaging for Hexagon Sockets .....	41
II Protrusion Gaging of Flat Countersunk Heads .....	43
III Type VI Recess Dimensions .....	45
<b>Nonmandatory Appendices</b>	
A Drill and Counterbore Sizes for Socket Head Cap Screws .....	48
B Formulas for Dimensions .....	51
C Hexagon Socket Head Cap Screws (1936 Series) .....	53

# FOREWORD

American National Standards Committee B18 for the standardization of bolts, screws, nuts, rivets, and similar fasteners was organized in March 1922 as Sectional Committee B18 under the aegis of the American Engineering Standards Committee (later the American Standards Association, then the United States of America Standards Institute and, as of October 6, 1969, the American National Standards Institute) with the Society of Automotive Engineers and the American Society of Mechanical Engineers as joint sponsors.

Subcommittee No. 9<sup>1</sup> on Socket Head Cap and Set Screws was organized in April 1929 and completed its first report in November 1931. Seven successive drafts were issued during which the content of the proposal was considerably extended and refined, and in March 1933, copies were distributed to industry for criticism and comment. The suggestions received were carefully reviewed, and in April 1935, the proposal was presented to the members of Sectional Committee B18 for letter ballot vote. Following the acceptance by the two sponsor organizations, it was designated as an American Standard (ASA B18.3) in February 1936 by the American Standards Association.

For the purpose of keeping the work of the Subcommittee in line with the developments in industry, the Committee prepared a supplement to the standard in the form of a table covering the dimensions of hexagonal and fluted socket head shoulder screws (stripper bolts) optional, which received approval of the American Standards Association in April 1944 and was designated ASA B18.3a.

In March 1945, the Subcommittee submitted certain fundamental changes and additions to the Standard, and the Sectional Committee recommended issuance of a completely revised standard. Following approval of the Sectional Committee, the revised document was approved by the sponsor organizations and the American Standards Association and designated an American Standard in April 1947.

In accordance with ASA procedure, a review of the standard was undertaken in 1950 and certain additional changes were recommended by the Subcommittee. Cap screw sizes No. 0 and 1 and set screw sizes No. 0, 1, 2, 3, and 4 were added to satisfy increasing demand from various industries. Material, hardness, and thread fit were included to provide a more complete standard. A draft dated November 1951 was distributed to industry

for criticism and comment. A further revision, dated November 1953, was presented to Sectional Committee B18 for letter ballot vote. Following approval of the Sectional Committee and sponsors, the proposal was submitted to the American Standards Association. It was approved and designated an American Standard on August 26, 1954.

Shortly after the 1954 standard was issued, work was initiated on the development of standards covering flat countersunk head cap screws, button head cap screws, and cap screws up to 4 in. in diameter. As these proposals evolved with comments received from various industries, it became evident that a major revision was required, particularly in regard to insufficient bearing surface under the head on some sizes as well as increased socket sizes to permit higher set-up torque. The resulting proposed revision was presented to Sectional Committee B18 for letter ballot vote. Following approval of the Sectional Committee and sponsors, the proposal was submitted to the American Standards Association. It was approved and designated an American Standard on December 21, 1961.

Continued surveillance of the 1961 standard by the Subcommittee indicated by 1966 that a complete revision of the document was necessary to provide recognition of technical improvements in materials and manufacturing methods. Work over the next 2 years culminated in a March 1968 draft proposal incorporating revisions in the following areas:

- (a) more clearly defined materials for all products
- (b) application of Unified radius root threads to all cap screws
- (c) refinements to underhead fillets
- (d) extension of size coverage for flat countersunk head cap screws to include  $\frac{7}{8}$  in. through  $1\frac{1}{2}$  in. diameters, and tabulation of body and grip lengths for sizes 0 in. through 1 in.
- (e) increased key engagements in socket set screws and implementation of minimum hexagon key engagement in short length set screws
- (f) addition of width across corner dimensions for hexagon keys and bits
- (g) the inclusion of appendices covering drill and counterbore sizes for socket head cap screws (1960 Series), and gages and gaging for spline sockets.

Following acceptance of this draft by the Subcommittee, it was approved by letter ballot of USA Standards Committee B18 and the sponsor organizations, and submitted to the United States of America

<sup>1</sup> As of April 1, 1966, Subcommittee 9 was redesignated as Subcommittee 3.

Standards Institute. It was approved and designated a USA Standard on September 19, 1969.

A periodic review of the standard, undertaken by Subcommittee 3 in 1973, resulted in agreement that the document be revised to reflect clarification of the underhead fillet on socket head cap screws, add coverage on drilled socket head cap screws, lengthen the thread undercut on socket head shoulder screws, and extend the coverage on the latter to include the 1½-in., 1¾-in., and 2-in. sizes. A proposal incorporating these changes together with numerous editorial corrections was prepared and, subsequent to Subcommittee acceptance, approved by letter ballot to American National Standards Committee B18. Following approval by the sponsor organizations, the proposal was submitted to the American National Standards Institute and designated an American National Standard on November 1, 1976.

A periodic review of the standard, undertaken by the Subcommittee in 1980, resulted in agreement that the document be revised

- (a) to clarify the notes on screw point chamfers
- (b) in socket tolerances for large sockets and in counterbore sizes to reflect standard tooling
- (c) to reference ASTM A574 for the appropriate mechanical and chemical requirements

A proposal containing these changes, as well as many editorial corrections, was prepared for and balloted by letter ballot to the ASME Committee B18. Following approval by the sponsor organization, the proposal was submitted to the American National Standards Institute and designated an American National Standard on January 4, 1982.

A periodic review of the standard, undertaken by the Committee in 1985, resulted in agreement that the document be revised to clarify the dimensions with respect to plated products, and to incorporate by reference the new ASTM documents for the appropriate mechanical, chemical, and testing requirements for the button head, flat countersunk head, and set screw products. A proposal containing these changes, as well as editorial corrections, was prepared and balloted by letter ballot to ASME Committee B18. Following approval by ASME, the proposal was submitted to the American National Standards Institute and designated an American National Standard on August 7, 1986.

A periodic review of this Standard was undertaken by the Committee in 1990. Based on this review, it was

determined that the document needed significant revisions to clarify and update the Standard. These revisions would need to address the technical changes in manufacturing methods and changes in the standards community. To accomplish this objective, established quality standards were recognized and integrated into the Standard. In addition, designated characteristics for each product and product identification were established and gaging techniques for countersunk screws were added. These changes were balloted and approved by the ASME B18 Committee. The proposal was submitted to the American National Standards Institute and designated an American National Standard on January 14, 1998.

A periodic review of this Standard was again undertaken by the Committee in 2000. It was determined that there were many technical printing errors that had to be revised. Inspection definitions were added to clarify bearing surface, runout, and straightness for various products. The radius under the head for socket head screws was clarified by the addition of drawings showing the radius on thread to the head socket screws, and also showing the radius on socket screws with an unthreaded shoulder. The protrusion gage dimensions were changed on flat head socket cap screws. The thread requirements for short length socket set screws were also changed. A standard was also developed for low head socket cap screws. These changes were balloted and approved by the ASME B18 Committee. The proposal was submitted to the American National Standards Institute and designated as an American National Standard on July 8, 2003.

In 2010, a task group was formed to review this Standard. The current revision is a result of their work. Spline driven fasteners, and their associated keys, have been removed from the document and users that wish to use this type of fastener will need to refer to the previous edition. The Type VI (Six Lobe) drive style has been added as a mandatory appendix. The tolerance for protrusion requirements on flat head socket cap screws has been increased. An alternative method for measuring protrusion has been included and corresponds with the metric document ISO 10642.

Other less significant changes in this revision include the addition of some sizes and slight changes to the requirements for drilled heads.

This Standard was approved by the American National Standards Institute on November 16, 2012.

# ASME B18 COMMITTEE

## Standardization of Bolts, Nuts, Rivets, Screws, Washers, and Similar Fasteners

(The following is the roster of the Committee at the time of approval of this Standard.)

### STANDARDS COMMITTEE OFFICERS

**J. Greenslade**, *Chair*  
**D. S. George**, *Vice Chair*  
**W. H. King**, *Vice Chair*  
**C. J. Gomez**, *Secretary*

### STANDARDS COMMITTEE PERSONNEL

<b>V. Cartina</b> , Nylok	<b>M. D. Prasad</b> , <i>Contributing Member</i> , Global M & F Solutions, Inc.
<b>D. A. Clever</b> , <i>Contributing Member</i> , Consultant	<b>S. Savoji</b> , <i>Contributing Member</i> , ITW Medalist
<b>A. P. Cockman</b> , Ford Motor Co.	<b>Q. M. Smith III</b> , Oregon DOT
<b>C. D. de la Garza</b> , TSP, Inc.	<b>D. J. Soscia</b> , General Dynamics Electric Boat Corp.
<b>D. S. George</b> , Ramco Specialties	<b>W. R. Stevens</b> , Consultant
<b>C. J. Gomez</b> , The American Society of Mechanical Engineers	<b>R. D. Strong</b> , Doerken Corp.
<b>J. Greenslade</b> , Industrial Fasteners Institute	<b>S. W. Vass</b> , <i>Contributing Member</i> , Consultant
<b>J. J. Grey</b> , <i>Contributing Member</i> , Fastener Consulting Services, Inc.	<b>C. B. Wackrow</b> , MNP Corp.
<b>A. Herskovitz</b> , <i>Contributing Member</i> , Consultant	<b>W. K. Wilcox</b> , Consultant
<b>J. Hubbard</b> , Leland-Powell Fasteners, Inc.	<b>C. B. Williamson</b> , Fastenal Co.
<b>J. Jennings</b> , <i>Contributing Member</i> , Naval Surface Warfare Center	<b>C. J. Wilson</b> , Consultant
<b>W. H. King</b> , Porteous Fastener Co.	<b>J. G. Zeratsky</b> , <i>Contributing Member</i> , National Rivet and Manufacturing Co.

### SUBCOMMITTEE 3 – SOCKET HEAD, CAP, AND SET SCREWS

<b>C. B. Williamson</b> , <i>Chair</i> , Fastenal Co.	<b>J. Hubbard</b> , Leland-Powell Fasteners, Inc.
<b>J. Finnegan</b> , <i>Vice Chair</i> , Safety Socket LLC	<b>M. Keller</b> , Consultant
<b>A. L. Guzman</b> , <i>Secretary</i> , The American Society of Mechanical Engineers	<b>R. W. Kerr</b> , Kerr Lakeside, Inc.
<b>T. Anderson</b> , Bay Bolt	<b>W. H. King</b> , Porteous Fastener Co.
<b>V. Cartina</b> , Nylok	<b>M. L. Levinson</b> , ITW Shakeproof Industrial Products
<b>L. Claus</b> , ATF, Inc.	<b>J. F. McCarrick</b> , Defense Supply Center Philadelphia
<b>T. Collier</b> , Cam-Tech Industry, Inc.	<b>R. B. Meade</b> , Atrona Test Labs, Inc.
<b>C. Dugal de la Garza</b> , TSP, Inc.	<b>L. C. Schroeder</b> , Kansas Department of Transportation
<b>M. A. Elmi</b> , Caterpillar	<b>G. M. Simpson</b> , Semblex Corp.
<b>J. Foote</b> , Trade Association Management, Inc.	<b>D. J. Soscia</b> , General Dynamics Electric Boat Corp.
<b>D. S. George</b> , Ramco Specialties	<b>R. D. Strong</b> , Doerken Corp.
<b>J. Greenslade</b> , Industrial Fasteners Institute	<b>C. B. Wackrow</b> , MNP Corp.
<b>J. J. Grey</b> , Fastener Consulting Services, Inc.	<b>P. H. Werner</b> , Safety Socket Screw Corp.
<b>A. Herskovitz</b> , Consultant	<b>W. K. Wilcox</b> , Consultant
	<b>C. J. Wilson</b> , Consultant
	<b>D. Winn</b> , Kamax



# CORRESPONDENCE WITH THE B18 COMMITTEE

**General.** ASME Standards are developed and maintained with the intent to represent the consensus of concerned interests. As such, users of this Standard may interact with the Committee by requesting interpretations, proposing revisions, and attending Committee meetings. Correspondence should be addressed to:

Secretary, B18 Standards Committee  
The American Society of Mechanical Engineers  
Two Park Avenue  
New York, NY 10016-5990  
<http://go.asme.org/Inquiry>

**Proposing Revisions.** Revisions are made periodically to the Standard to incorporate changes that appear necessary or desirable, as demonstrated by the experience gained from the application of the Standard. Approved revisions will be published periodically.

The Committee welcomes proposals for revisions to this Standard. Such proposals should be as specific as possible, citing the paragraph number(s), the proposed wording, and a detailed description of the reasons for the proposal, including any pertinent documentation.

**Proposing a Case.** Cases may be issued for the purpose of providing alternative rules when justified, to permit early implementation of an approved revision when the need is urgent, or to provide rules not covered by existing provisions. Cases are effective immediately upon ASME approval and shall be posted on the ASME Committee Web page.

Requests for Cases shall provide a Statement of Need and Background Information. The request should identify the Standard, the paragraph, figure or table number(s), and be written as a Question and Reply in the same format as existing Cases. Requests for Cases should also indicate the applicable edition(s) of the Standard to which the proposed Case applies.

**Interpretations.** Upon request, the B18 Committee will render an interpretation of any requirement of the Standard. Interpretations can only be rendered in response to a written request sent to the Secretary of the B18 Standards Committee.

The request for interpretation should be clear and unambiguous. It is further recommended that the inquirer submit his/her request in the following format:

Subject: Cite the applicable paragraph number(s) and the topic of the inquiry.  
Edition: Cite the applicable edition of the Standard for which the interpretation is being requested.  
Question: Phrase the question as a request for an interpretation of a specific requirement suitable for general understanding and use, not as a request for an approval of a proprietary design or situation. The inquirer may also include any plans or drawings that are necessary to explain the question; however, they should not contain proprietary names or information.

Requests that are not in this format may be rewritten in the appropriate format by the Committee prior to being answered, which may inadvertently change the intent of the original request.

ASME procedures provide for reconsideration of any interpretation when or if additional information that might affect an interpretation is available. Further, persons aggrieved by an interpretation may appeal to the cognizant ASME Committee or Subcommittee. ASME does not "approve," "certify," "rate," or "endorse" any item, construction, proprietary device, or activity.

**Attending Committee Meetings.** The B18 Standards Committee regularly holds meetings that are open to the public. Persons wishing to attend any meeting should contact the Secretary of the B18 Standards Committee.

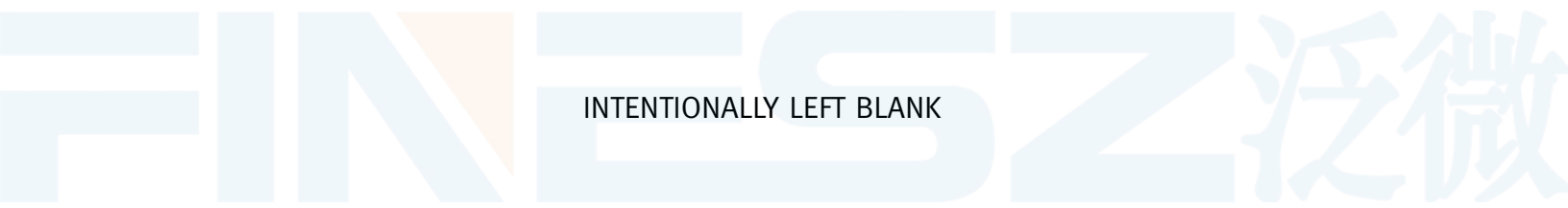

INTENTIONALLY LEFT BLANK

# SOCKET CAP, SHOULDER, SET SCREWS, AND HEX KEYS (INCH SERIES)

## 1 INTRODUCTORY NOTES

### 1.1 Scope

This Standard covers complete general and dimensional data for various types of hexagon socket cap screws, shoulder screws, set screws, and hexagon keys recognized as an American National Standard. Also included are appendices that provide specifications for hexagon socket gages and gaging, tables showing applicability of keys and bits to various socket screw types and sizes, drill and counterbore sizes for socket head cap screws, and formulas used for dimensional data. However, where questions arise concerning acceptance of product, the dimensions in the tables shall govern over recalculation by formula. Recess dimensions for Type VI recesses are given in Mandatory Appendix III.

### 1.2 Socket Cap Screws

The head types covered by this Standard are specified in paras. 1.2.1 through 1.2.5.

**1.2.1 Socket Head Cap Screws.** The socket head shall have a flat chamfered top surface with smooth or knurled cylindrical sides and a flat bearing surface. Specifications are given in Tables 1 through 7. Dimensions for drilled holes and counterbores are included in Table A-1 of Nonmandatory Appendix A.

**1.2.2 Drilled Hexagon Socket Head Cap Screws.** Specifications for hexagon socket head cap screws having two, four, and six holes drilled in the head for lock wire applications are given in Table 7.

**1.2.3 Socket Flat Countersunk Head Cap Screws.** The flat countersunk head shall have a flat top surface and a conical-bearing surface with an angle of approximately 82 deg. Specifications are given in Tables 8 through 10.

**1.2.4 Socket Button Head Cap Screws.** The button head shall have a low rounded top surface with a large flat bearing surface. Specifications are given in Table 11.

**1.2.5 Socket Low Head Cap Screws.** These are similar to socket head cap screws, except they have reduced head height and a smaller socket size. They are designed to be used in applications where height clearance is a problem. Specifications are given in Table 12.

### 1.3 Socket Head Shoulder Screws

The socket head shoulder screw is a hexagon socket head screw having a cylindrical shoulder under the head. Specifications are given in Table 13.

### 1.4 Socket Set Screws

The socket set screw is a screw threaded the entire length except for its length of point. The point is designed to bear on a mating part. The common point styles are cup, flat, oval, cone, and half dog. Specifications for set screws are shown in Tables 14 through 16.

### 1.5 Keys and Bits for Driving Socket Screws

The tools for driving socket screws are hexagon keys and bits. Table 17 contains the requirements for hexagon keys and bits.

### 1.6 Dimensions

All dimensions in this Standard are given in inches unless stated otherwise. All dimensions apply prior to coating unless stated otherwise.

### 1.7 Finish

Because of the high hardness of these products, it is recommended that they not be electroplated.

### 1.8 Identification Marking

Products described in paras. 1.2.1 through 1.2.4 and 1.3 with diameters larger than #10 shall be marked with the identification of the source manufacturer or private label distributor accepting the responsibility for conformance to this Standard. Marking size, type, and location of marks are at manufacturer's option. Products shall not be marked on bearing surface.

### 1.9 Terminology

For definitions of terms relating to fasteners or to component features thereof used in this Standard, refer to ASME B18.12, Glossary of Terms for Mechanical Fasteners.

### 1.10 Responsibility for Modifications

The manufacturer shall not be held responsible for malfunctions of product due to plating or other modifications, when such plating or modification is not accomplished under his control or direction.

### 1.11 Referenced Standards

The following is a list of publications referenced in this Standard. Unless otherwise specified, the most recent standard available shall be used.

ASME B1.1, Unified Inch Screw Threads, (UN and UNR Thread Form)

ASME B1.3, Screw Thread Gaging Systems for Acceptability — Inch and Metric Screw Threads (UN, UNR, UNJ, M, and MJ)

ASME B18.2.9, Straightness Gage and Gaging for Bolts and Screws

ASME B18.12, Glossary of Terms for Mechanical Fasteners

ASME B18.18, Quality Assurance for Fasteners

ASME B18.24, Part Identifying Number (PIN) Code System Standard for B18 Fastener Products

ASME B46.1, Surface Texture (Surface Roughness, Waviness, and Lay)

ASME B47.1, Gage Blanks

ASME Y14.5, Dimensioning and Tolerancing

ASME Y14.6, Screw Thread Representation

Publisher: The American Society of Mechanical Engineers (ASME), Two Park Avenue, New York, NY 10016-5990; Order Department: 22 Law Drive, P. O. Box 2900, Fairfield, NJ 07007-2900 (www.asme.org)

ASTM A574, Standard Specification for Alloy Steel Socket Head Cap Screws

ASTM F835, Standard Specification for Alloy Steel Socket Button and Flat Countersunk Head Cap Screws

ASTM F837, Standard Specification for Stainless Steel Socket Head Cap Screws

ASTM F879, Standard Specification for Stainless Steel Socket Button and Flat Countersunk Head Cap Screws

ASTM F880, Standard Specification for Stainless Steel Socket Set Screws

ASTM F912, Standard Specification for Alloy Steel Socket Set Screws

ASTM F1941, Standard Specification for Electrodeposited Coatings on Threaded Fasteners

Publisher: American Society for Testing and Materials (ASTM International), 100 Barr Harbor Drive, P. O. Box C700, West Conshohocken, PA 19428-2959 (www.astm.org)

## 2 GENERAL DATA

### 2.1 Sockets

Unless otherwise specified, screws shall have hexagon sockets in accordance with the provisions set forth in the notes to the respective dimensional tables.

**2.1.1 Hexagon Sockets.** Hexagon sockets shall conform to the specifications given in Table 18. Gages and gaging procedures are included in Mandatory Appendix I.

**2.1.2 Type VI Sockets.** Type VI recesses shall conform to the specifications given in Mandatory Appendix III. Gages and gaging procedures are included in Mandatory Appendix III.

### 2.2 Threads

Threads on all screw products covered by this Standard shall be in accordance with ASME B1.1 for the series and class specified in the notes to the respective product dimensional tables.

Acceptability of screw threads shall be based on System 22, ASME B1.3, except where otherwise specified in Note (12) of Table 14.

### 2.3 Quality Assurance

Products shall be furnished in accordance with category 2 of ASME B18.18. The requirements from other relative standards, such as ASTM A574 or ASTM F1941, shall apply.

**Table 1 Dimensions of Hexagon Socket Head Cap Screws**

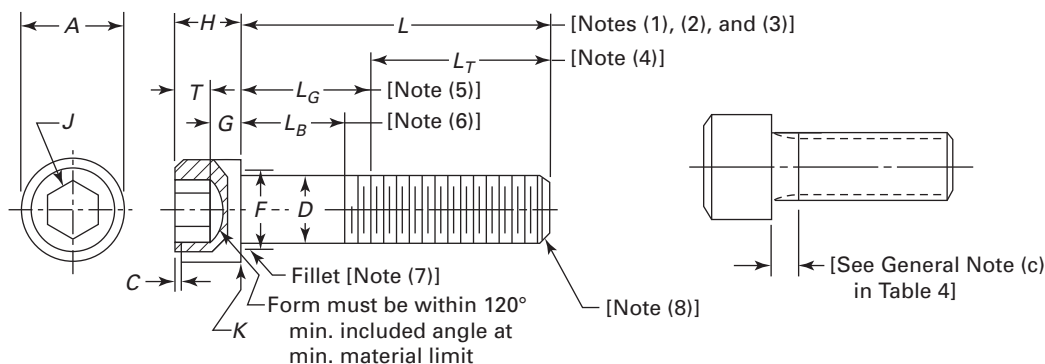

Nominal Size (Basic Screw Diameter) [Note (7)]	Body Diameter, <i>D</i> [Notes (8) and (9)]		Head Diameter, <i>A</i> [Note (10)]		Head Height, <i>H</i>		Maximum Chamfer or Radius, <i>C</i> [Note (11)]	Nominal Hexagon Socket Size, <i>J</i> [Note (12)]	Minimum Key Engage- ment, <i>T</i>	Minimum Wall Thickness, <i>G</i>	Maximum Chamfer or Radius, <i>K</i> [Note (13)]		
	Max.	Min.	Max.	Min.	Max.	Min.							
0	(0.0600)	0.0600	0.0568	0.096	0.091	0.060	0.057	0.004	...	0.050	0.025	0.020	0.007
1	(0.0730)	0.0730	0.0695	0.118	0.112	0.073	0.070	0.005	1/16	0.062	0.031	0.025	0.007
2	(0.0860)	0.0860	0.0822	0.140	0.134	0.086	0.083	0.008	5/64	0.078	0.038	0.029	0.007
3	(0.0990)	0.0990	0.0949	0.161	0.154	0.099	0.095	0.008	5/64	0.078	0.044	0.034	0.007
4	(0.1120)	0.1120	0.1075	0.183	0.176	0.112	0.108	0.009	3/32	0.094	0.051	0.038	0.008
5	(0.1250)	0.1250	0.1202	0.205	0.198	0.125	0.121	0.012	3/32	0.094	0.057	0.043	0.008
6	(0.1380)	0.1380	0.1329	0.226	0.216	0.138	0.134	0.013	7/64	0.109	0.064	0.047	0.008
8	(0.1640)	0.1640	0.1585	0.270	0.257	0.164	0.159	0.014	9/64	0.141	0.077	0.056	0.008
10	(0.1900)	0.1900	0.1840	0.312	0.298	0.190	0.185	0.018	5/32	0.156	0.090	0.065	0.008
12	(0.2160)	0.2160	0.2095	0.324	0.314	0.216	0.210	0.022	5/32	0.156	0.103	0.082	0.010
1/4	(0.2500)	0.2500	0.2435	0.375	0.354	0.250	0.244	0.025	3/16	0.188	0.120	0.095	0.010
5/16	(0.3125)	0.3125	0.3053	0.469	0.446	0.312	0.306	0.033	1/4	0.250	0.151	0.119	0.010
3/8	(0.3750)	0.3750	0.3678	0.562	0.540	0.375	0.368	0.040	5/16	0.312	0.182	0.143	0.010
7/16	(0.4375)	0.4375	0.4294	0.656	0.631	0.438	0.430	0.047	3/8	0.375	0.213	0.166	0.015
1/2	(0.5000)	0.5000	0.4919	0.750	0.725	0.500	0.492	0.055	3/8	0.375	0.245	0.190	0.015
9/16	(0.5625)	0.5625	0.5538	0.843	0.827	0.562	0.554	0.062	7/16	0.437	0.276	0.214	0.015
5/8	(0.6250)	0.6250	0.6163	0.938	0.914	0.625	0.616	0.070	1/2	0.500	0.307	0.238	0.015
3/4	(0.7500)	0.7500	0.7406	1.125	1.094	0.750	0.740	0.085	5/8	0.625	0.370	0.285	0.015
7/8	(0.8750)	0.8750	0.8647	1.312	1.291	0.875	0.864	0.100	3/4	0.750	0.432	0.333	0.020
1	(1.0000)	1.0000	0.9886	1.500	1.476	1.000	0.988	0.114	3/4	0.750	0.495	0.380	0.020
1 1/8	(1.1250)	1.1250	1.1086	1.688	1.665	1.125	1.111	0.129	7/8	0.875	0.557	0.428	0.020
1 1/4	(1.2500)	1.2500	1.2336	1.875	1.852	1.250	1.236	0.144	7/8	0.875	0.620	0.475	0.020
1 3/8	(1.3750)	1.3750	1.3568	2.062	2.038	1.375	1.360	0.160	1	1.000	0.682	0.523	0.020
1 1/2	(1.5000)	1.5000	1.4818	2.250	2.224	1.500	1.485	0.176	1	1.000	0.745	0.570	0.020
1 3/4	(1.7500)	1.7500	1.7295	2.625	2.597	1.750	1.734	0.207	1 1/4	1.250	0.870	0.665	0.020
2	(2.0000)	2.0000	1.9780	3.000	2.970	2.000	1.983	0.238	1 1/2	1.500	0.995	0.760	0.020
2 1/4	(2.2500)	2.2500	2.2280	3.375	3.344	2.250	2.232	0.269	1 3/4	1.750	1.120	0.855	0.036
2 1/2	(2.5000)	2.5000	2.4762	3.750	3.717	2.500	2.481	0.300	1 3/4	1.750	1.245	0.950	0.036
2 3/4	(2.7500)	2.7500	2.7262	4.125	4.090	2.750	2.730	0.332	2	2.000	1.370	1.045	0.036
3	(3.0000)	3.0000	2.9762	4.500	4.464	3.000	2.979	0.363	2 1/4	2.250	1.495	1.140	0.036
3 1/4	(3.2500)	3.2500	3.2262	4.875	4.837	3.250	3.228	0.394	2 1/4	2.250	1.620	1.235	0.036
3 1/2	(3.5000)	3.5000	3.4762	5.250	5.211	3.500	3.478	0.426	2 3/4	2.750	1.745	1.330	0.036
3 3/4	(3.7500)	3.7500	3.7262	5.625	5.584	3.750	3.727	0.458	2 3/4	2.750	1.870	1.425	0.036
4	(4.0000)	4.0000	3.9762	6.000	5.958	4.000	3.976	0.489	3	3.000	1.995	1.520	0.036

**Table 1 Dimensions of Hexagon Socket Head Cap Screws (Cont'd)**

GENERAL NOTE: For additional requirements, refer to Notes (14) through (21), and also section 2, General Data, at the beginning of this Standard.

NOTES:

- (1) *Length*. The length of the screw shall be measured parallel to the axis of the screw from the plane of the bearing surface under the head to the plane of the flat of the point. The portion of the screw contained within dimension  $L$  is commonly called the *shank*. The basic length dimension on the product shall be the nominal length expressed as a two-placed decimal.
- (2) *Standard Lengths*. Standard length increments for socket head cap screws shall be as tabulated below.

Nominal Screw Size, in.	Nominal Screw Length, in.	Standard Length Increment
0 to 1.00, incl.	0.13 through 0.25	0.06
	0.25 through 1.00	0.13
	1.00 through 3.50	0.25
	3.50 through 7.00	0.50
	7.00 through 10.00	1.00
Over 1.00	1.00 through 7.00	0.50
	7.00 through 10.00	1.00
	Over 10.00	2.00

- (3) *Length Tolerances*. The allowable tolerance on length shall be as tabulated below.

Nominal Screw Length, in.	Nominal Screw Size, Tolerances on Lengths			
	0 Through $\frac{3}{8}$ , Incl.	$\frac{7}{16}$ Through $\frac{3}{4}$ , Incl.	$\frac{7}{8}$ Through $1\frac{1}{2}$ , Incl.	Over $1\frac{1}{2}$
Up to 1.00, incl.	-0.03	-0.03	-0.05	...
Over 1.00 to 2.50, incl.	-0.04	-0.06	-0.10	-0.18
Over 2.5 to 6.00, incl.	-0.06	-0.08	-0.14	-0.20
Over 6.00	-0.12	-0.12	-0.20	-0.24

- (4) *Thread Length  $L_T$* . The length of thread shall be measured, parallel to the axis of the screw, from the extreme point to the last complete (full-form) thread. The thread length on socket head cap screws shall be as defined by Table 4 and notes thereto.
- (5) *Grip Gaging Length  $L_G$* . Grip gaging length is the distance, measured parallel to the axis of the screw, from the bearing surface of the head to the first complete (full-form) thread under the head (see Table 4).
- (6) *Body Length  $L_B$* . Body length is the length, measured parallel to the axis of the screw, of the unthreaded portion of the shank (see Table 4).
- (7) *Fillet*. For all lengths of screws, the form of the underhead fillet shall be optional, as depicted in the illustration above Tables 2 and 3, provided it is a smooth and continuous concave curve fairing into the bearing surface of the head, and the screw shank is within the envelope established by the limits for fillet extension, length, and juncture radius specified in Tables 2 and 3.
- (8) *Screw Point Chamfer*. The point shall be flat or slightly concave and chamfered. The plane of the point shall be approximately normal to the axis of the screw. The chamfer shall extend slightly below the root of the thread, and the edge between the flat and chamfer may be slightly rounded. The included angle of the point should be approximately 90 deg. Chamfering of the screw sizes up to and including size 8 (0.164 in.) and lengths below  $0.75d$  shall be optional.
- (9) *Nominal Size*. Where specifying nominal size in decimals, zeros preceding decimal and in the fourth decimal place shall be omitted.
- (10) *Head Diameter*. Heads may be plain or knurled at the option of the manufacturer, unless specified otherwise by the customer. For knurled screws, the maximum head diameter shall be measured across the tops of the knurl, and the minimum head diameter shall be the diameter of the unknurled portion or the diameter across the tops of the knurl for those screws not having an unknurled portion, just above the radius or chamfer at the bottom edge of the head.
- (11) *Head Chamfer*. The top of the head shall be flat. The intersection of the top of the head and the side of the head may be chamfered or radiused within the limits of  $C$ , at the manufacturer's option.

**Table 1 Dimensions of Hexagon Socket Head Cap Screws (Cont'd)**

- (12) *Edge of Head.* The edge between the bearing surface and the side of the head may be broken (rounded or chamfered), but the radius or chamfer measured along the bearing surface shall not exceed the values listed for  $K$ .
- (13) *Bearing Surface.* The plane of the bearing surface shall be perpendicular to the axis of the shank, within a maximum deviation of 1 deg, obtained by holding the screw on the body or major thread diameter within 1 diameter of the bearing surface of the head, but beyond the maximum length of the fillet,  $F_L$ , and inspecting on an optical comparator, or comparable inspection equipment, rotating the axis of the shank 360 deg.
- (14) *Body.* The term *body* refers to the unthreaded cylindrical portion of the shank for those screws not threaded to the head.
- (15) See Table 18 for hexagon socket dimensions and Mandatory Appendix I for gaging of hexagon sockets.
- (16) *Runout*
- (a) The runout of the head with the axis of the shank shall be within 2% of the maximum basic screw diameter dimension,  $D$ , or 0.006 in., whichever is greater.
- Runout for (a) above is defined as the full indicator movement (FIM) obtained by holding the screw on the body or major screw thread diameter within 1 diameter of the bearing surface of the head, but beyond the maximum length of the fillet,  $F_L$ , rotating 360 deg and indicating on the outside diameter of the head.
- (b) The runout of the socket with the axis of the shank of the screw shall be within 3% of the maximum screw diameter,  $D$ , or 0.005 in., whichever is greater for nominal sizes through  $\frac{1}{2}$  in. diameter and 6% for nominal sizes above  $\frac{1}{2}$  in. diameter.
- Runout for (b) above is defined as the full indicator movement (FIM) obtained by holding the screw on the body or major screw thread diameter within 1 diameter of the bearing surface of the head, but beyond the maximum length of the fillet,  $F_L$ , rotating 360 deg, indicating on each of six hexagon flats.
- (c) The conformance of screws to shank straightness or camber limitations set forth as  $D_e$  in Table 6, shall be checked by the use of the procedures and typical gage illustrated in ASME B18.2.9.
- (17) *Threads.* Threads shall be Unified external threads with radius root: Class 3A UNRC and UNRF Series for screw sizes 0 (0.060 in.) through 1 in.; Class 2A UNRC and UNRF Series for sizes over 1 in. to  $1\frac{1}{2}$  in., inclusive; and Class 2A UNR Series for sizes larger than  $1\frac{1}{2}$  in.
- For plated or unplated screws, acceptability shall be based upon System 22, ASME B1.3.
- Class 3A does not provide a plating allowance.
- (18) *Material*
- (a) *Steel, Alloy.* Cap screws shall be fabricated from an alloy steel and shall conform in all respects to ASTM A574.
- (b) *Steel, Corrosion-Resistant.* Cap screws shall be fabricated from a corrosion-resistant steel and shall conform to ASTM F837.
- (19) *Surface Roughness.* For alloy steel screws of sizes up to and including  $\frac{5}{8}$  in., and nominal lengths equal to or less than 8 times the basic screw diameter, the surface roughness of the screws shall not exceed 63  $\mu$ in. (arithmetical average) on the fillet and head bearing surfaces, nor exceed 32  $\mu$ in. (arithmetical average) on the threads.
- For larger sizes, longer lengths, and corrosion-resistant steel screws, the surface roughness of the screws shall not exceed 125  $\mu$ in. (arithmetical average) on the body [see Note (8)], fillet [see Note (14)], and head bearing surfaces.
- Normally, it shall be sufficient to ascertain that these surfaces on screws have the equivalent of a smooth machined finish by visual comparison with known surface standards. However, where it is practical and deemed necessary to measure these surfaces with commercially available equipment, roughness measurements shall be taken axially on the body and fillet surfaces, and circumferentially on the bearing surface. (See ASME B46.1, Surface Texture.)
- (20) *Drawings.* On socket screw drawings, when the distance from the bearing surface of the head to the threading is dimensioned, regardless of type of thread representation (see ASME Y14.6 for description of schematic and simplified thread representation), the dimension should be noted to indicate whether body length or grip length is required.
- (21) *Designation.* To promote uniformity and understanding in communications relating to products conforming to this Standard, it is recommended that Hexagon Socket Head Cap Screws be designated in accordance with the following data, preferably in the sequence shown:
- (a) product name  
 (b) designation of the standard  
 (c) nominal size (number, fractional or decimal equivalent)  
 (d) thread pitch  
 (e) nominal length (fractional or decimal equivalent)  
 (f) material  
 (g) protective finish, if required
- EXAMPLES:  
 Hexagon Socket Head Cap Screws, ASME B18.3, 6-32  $\times$   $\frac{3}{4}$ , Alloy Steel

For the recommended B18 part identifying numbering system (PIN), see ASME B18.24.

**Table 2 Dimensions of Under Head Fillets for Socket Head Cap Screws Threaded to the Head**

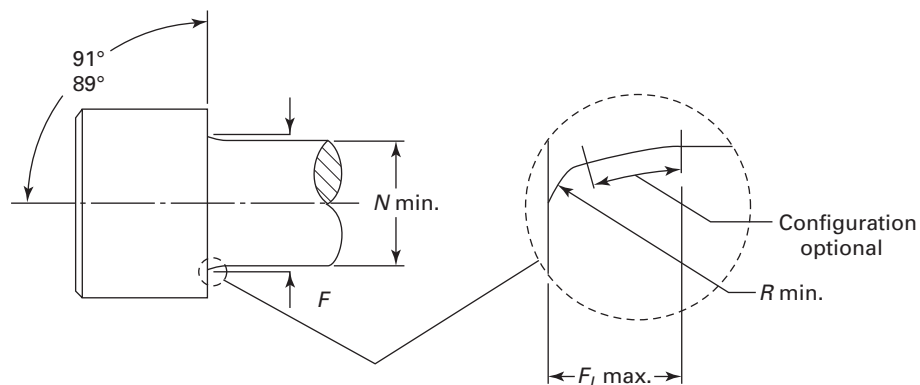

Nominal Size (Basic Screw Diameter)	Before Threading Diameter, Min., $N$	Fillet Junction Diameter at Bearing Surface, $F$		Maximum Fillet Length, $F_L$	Minimum Juncture Radius, $R$
		Max.	Min.		
0 (0.0600)	0.051	0.074	0.062	0.012	0.002
1 (0.0730)	0.061	0.087	0.075	0.012	0.003
2 (0.0860)	0.073	0.102	0.090	0.014	0.003
3 (0.0990)	0.084	0.115	0.102	0.014	0.004
4 (0.1120)	0.094	0.130	0.117	0.015	0.004
5 (0.1250)	0.107	0.145	0.132	0.017	0.005
6 (0.1380)	0.116	0.158	0.144	0.017	0.005
8 (0.1640)	0.142	0.188	0.172	0.020	0.006
10 (0.1900)	0.160	0.218	0.202	0.024	0.006
$\frac{1}{4}$ (0.2500)	0.215	0.278	0.261	0.024	0.007
$\frac{5}{16}$ (0.3125)	0.273	0.347	0.329	0.029	0.009
$\frac{3}{8}$ (0.3750)	0.331	0.415	0.397	0.034	0.012
$\frac{7}{16}$ (0.4375)	0.388	0.484	0.465	0.039	0.014
$\frac{1}{2}$ (0.5000)	0.446	0.552	0.531	0.044	0.016
$\frac{5}{8}$ (0.6250)	0.562	0.689	0.664	0.054	0.021
$\frac{3}{4}$ (0.7500)	0.681	0.828	0.800	0.066	0.025
$\frac{7}{8}$ (0.8750)	0.798	0.963	0.932	0.075	0.031
1 (1.0000)	0.914	1.100	1.068	0.085	0.034
$1\frac{1}{8}$ (1.1250)	1.023	1.235	1.198	0.094	0.039
$1\frac{1}{4}$ (1.2500)	1.148	1.370	1.333	0.102	0.044
$1\frac{3}{8}$ (1.3750)	1.256	1.505	1.466	0.110	0.048
$1\frac{1}{2}$ (1.5000)	1.381	1.640	1.601	0.119	0.052
$1\frac{3}{4}$ (1.7500)	1.609	1.910	1.869	0.136	0.062
2 (2.0000)	1.843	2.180	2.128	0.153	0.071
$2\frac{1}{4}$ (2.2500)	2.093	2.450	2.398	0.170	0.080
$2\frac{1}{2}$ (2.5000)	2.324	2.720	2.662	0.187	0.088
$2\frac{3}{4}$ (2.7500)	2.574	2.990	2.936	0.204	0.097
3 (3.0000)	2.824	3.260	3.206	0.221	0.106
$3\frac{1}{4}$ (3.2500)	3.073	3.530	3.476	0.238	0.114
$3\frac{1}{2}$ (3.5000)	3.323	3.800	3.746	0.255	0.124
$3\frac{3}{4}$ (3.7500)	3.573	4.070	4.016	0.272	0.134
4 (4.0000)	3.823	4.340	4.286	0.289	0.143

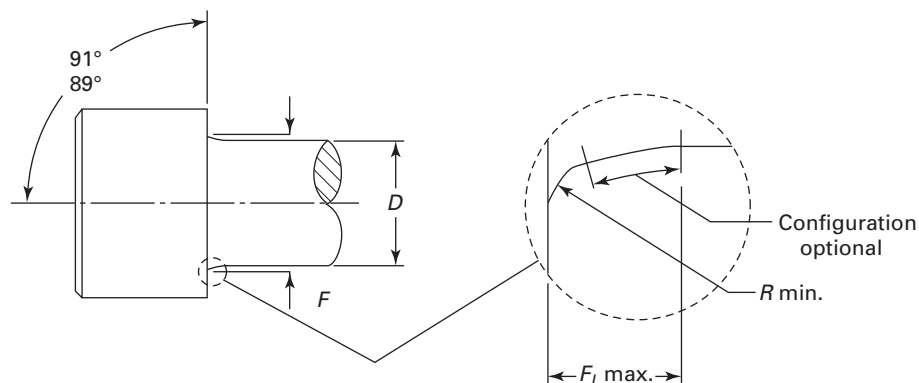

**Table 3 Dimensions of Under Head Fillets for Socket Head Cap Screws With an Unthreaded Length of Body Diameter**

Nominal Size (Basic Screw Diameter)	Body Diameter, <i>D</i>		Fillet Juncture Diameter at Bearing Surface, <i>F</i>		Maximum Fillet Length, <i>F<sub>L</sub></i>	Minimum Juncture Radius, <i>R</i>
	Max.	Min.	Max.	Min.		
0 (0.0600)	0.0600	0.0560	0.074	0.062	0.012	0.002
1 (0.0730)	0.0730	0.0695	0.087	0.075	0.012	0.003
2 (0.0860)	0.0860	0.0822	0.102	0.090	0.014	0.003
3 (0.0990)	0.0990	0.0949	0.115	0.102	0.014	0.004
4 (0.1120)	0.1120	0.1075	0.130	0.117	0.015	0.004
5 (0.1250)	0.1250	0.1202	0.145	0.132	0.017	0.005
6 (0.1380)	0.1380	0.1329	0.158	0.144	0.017	0.005
8 (0.1640)	0.1640	0.1585	0.188	0.172	0.020	0.006
10 (0.1900)	0.1900	0.1840	0.218	0.202	0.024	0.006
1/4 (0.2500)	0.2500	0.2435	0.278	0.261	0.024	0.007
5/16 (0.3125)	0.3125	0.3053	0.347	0.329	0.029	0.009
3/8 (0.3750)	0.3750	0.3678	0.415	0.397	0.034	0.012
7/16 (0.4375)	0.4375	0.4294	0.484	0.465	0.039	0.014
1/2 (0.5000)	0.5000	0.4919	0.552	0.531	0.044	0.016
5/8 (0.6250)	0.6250	0.6163	0.689	0.664	0.054	0.021
3/4 (0.7500)	0.7500	0.7406	0.828	0.800	0.066	0.025
7/8 (0.8750)	0.8750	0.8647	0.963	0.932	0.075	0.031
1 (1.0000)	1.0000	0.9886	1.100	1.068	0.085	0.034
1 1/8 (1.1250)	1.1250	1.1086	1.235	1.198	0.094	0.039
1 1/4 (1.2500)	1.2500	1.2336	1.370	1.333	0.102	0.044
1 3/8 (1.3750)	1.3750	1.3568	1.505	1.466	0.110	0.048
1 1/2 (1.5000)	1.5000	1.4818	1.640	1.601	0.119	0.052
1 3/4 (1.7500)	1.7500	1.7295	1.910	1.869	0.136	0.062
2 (2.0000)	2.0000	1.9780	2.180	2.128	0.153	0.071
2 1/4 (2.2500)	2.2500	2.2280	2.450	2.398	0.170	0.080
2 1/2 (2.5000)	2.5000	2.4762	2.720	2.662	0.187	0.088
2 3/4 (2.7500)	2.7500	2.7262	2.990	2.936	0.204	0.097
3 (3.0000)	3.0000	2.9762	3.260	3.206	0.221	0.106
3 1/4 (3.2500)	3.2500	3.2262	3.530	3.476	0.238	0.114
3 1/2 (3.5000)	3.5000	3.4762	3.800	3.746	0.255	0.124
3 3/4 (3.7500)	3.7500	3.7262	4.070	4.016	0.272	0.134
4 (4.0000)	4.0000	3.9762	4.340	4.286	0.289	0.143

Table 4 Body and Grip Lengths for Socket Head Cap Screws

Nominal Size	0		1		2		3		4		5		6		8		10 & 12	
	$L_G$	$L_B$	$L_G$	$L_B$	$L_G$	$L_B$	$L_G$	$L_B$	$L_G$	$L_B$	$L_G$	$L_B$	$L_G$	$L_B$	$L_G$	$L_B$	$L_G$	$L_B$
0.75	0.25	0.19	...	...	...	...	...	...	...	...	...	...	...	...	...	...	...	...
0.88	0.25	0.19	0.25	0.17	0.25	0.16	0.25	0.15	...	...	...	...	...	...	...	...	...	...
1.00	0.50	0.44	0.25	0.17	0.25	0.16	0.25	0.15	0.25	0.12	0.25	0.12	...	...	...	...	...	...
1.25	0.75	0.69	0.62	0.55	0.62	0.54	0.62	0.52	0.25	0.12	0.25	0.12	0.50	0.34	0.38	0.22	0.38	0.17
1.50	...	...	0.88	0.80	0.88	0.79	0.88	0.77	0.75	0.62	0.75	0.62	0.50	0.34	0.38	0.22	0.38	0.17
1.75	...	...	...	...	1.12	1.04	1.12	1.02	0.75	0.62	0.75	0.62	1.00	0.84	0.88	0.72	0.88	0.67
2.00	...	...	...	...	1.38	...	1.38	1.27	1.25	1.12	1.25	1.12	1.00	0.84	0.88	0.72	0.88	0.67
2.25	...	...	...	...	...	...	...	...	1.25	1.12	1.25	1.12	1.50	1.34	1.38	1.22	1.38	1.17
2.50	...	...	...	...	...	...	...	...	...	...	1.75	1.62	1.50	1.34	1.38	1.22	1.38	1.17
2.75	...	...	...	...	...	...	...	...	...	...	...	...	2.00	1.84	1.88	1.72	1.88	1.67
3.00	...	...	...	...	...	...	...	...	...	...	...	...	...	...	1.88	1.72	1.88	1.67
3.25	...	...	...	...	...	...	...	...	...	...	...	...	...	2.38	2.22	2.38	2.17	2.17
3.50	...	...	...	...	...	...	...	...	...	...	...	...	...	...	...	...	2.38	2.17
3.75	...	...	...	...	...	...	...	...	...	...	...	...	...	...	...	...	2.88	2.67
4.00	...	...	...	...	...	...	...	...	...	...	...	...	...	...	...	...	2.88	2.67

**Table 4 Body and Grip Lengths for Socket Head Cap Screws (Cont'd)**

Nominal Size	1/4		5/16		3/8		7/16		1/2 and 9/16		5/8		3/4		7/8		1	
	L <sub>G</sub>	L <sub>B</sub>	L <sub>G</sub>	L <sub>B</sub>	L <sub>G</sub>	L <sub>B</sub>	L <sub>G</sub>	L <sub>B</sub>	L <sub>G</sub>	L <sub>B</sub>	L <sub>G</sub>	L <sub>B</sub>	L <sub>G</sub>	L <sub>B</sub>	L <sub>G</sub>	L <sub>B</sub>	L <sub>G</sub>	L <sub>B</sub>
1.50	0.50	0.25	...	...	...	...	...	...	...	...	...	...	...	...	...	...	...	...
1.75	0.50	0.25	0.62	0.35	0.50	0.19	...	...	...	...	...	...	...	...	...	...	...	...
2.00	1.00	0.75	0.62	0.35	0.50	0.19	0.62	0.27	...	...	...	...	...	...	...	...	...	...
2.25	1.00	0.75	1.12	0.85	1.00	0.69	0.62	0.27	0.75	0.36	...	...	...	...	...	...	...	...
2.50	1.50	1.25	1.12	0.85	1.00	0.69	1.12	0.77	0.75	0.36	0.75	0.30	...	...	...	...	...	...
2.75	1.50	1.25	1.62	1.35	1.50	1.19	1.12	0.77	0.75	0.36	0.75	0.30	...	...	...	...	...	...
3.00	2.00	1.75	1.62	1.35	1.50	1.19	1.62	1.27	1.50	1.12	0.75	0.30	...	...	...	...	...	...
3.25	2.00	1.75	2.12	1.85	2.00	1.69	1.62	1.27	1.50	1.12	1.50	1.04	1.00	0.50	...	...	...	...
3.50	2.50	2.25	2.12	1.85	2.00	1.69	2.12	1.77	1.50	1.12	1.50	1.04	1.00	0.50	1.00	0.44	1.00	0.38
3.75	2.50	2.25	2.62	2.35	2.50	2.19	2.12	1.77	2.25	1.86	1.50	1.04	1.00	0.50	1.00	0.44	1.00	0.38
4.00	3.00	2.75	2.62	2.35	2.50	2.19	2.22	2.27	2.25	1.86	2.25	1.80	2.00	1.50	2.00	2.44	2.00	1.38
4.25	3.00	2.75	3.12	2.85	3.00	2.69	2.62	2.27	2.25	1.86	2.25	1.80	2.00	1.50	2.00	2.44	3.00	2.38
4.50	3.50	3.25	3.12	2.85	3.00	2.69	3.12	2.77	3.00	2.62	2.25	1.80	2.00	1.50	2.00	2.44	3.00	2.38
4.75	3.50	3.25	3.62	3.35	3.50	3.19	3.12	2.77	3.00	2.62	3.00	2.54	2.00	1.50	2.00	2.44	3.00	2.38
5.00	4.00	3.75	3.62	3.35	3.50	3.19	3.62	3.27	3.00	2.62	3.00	2.54	2.00	1.50	2.00	2.44	3.00	2.38
5.25	...	...	4.12	3.85	4.00	3.69	3.62	3.27	3.75	3.36	3.00	2.54	2.00	1.50	2.00	2.44	3.00	2.38
5.50	...	...	4.12	3.85	4.00	3.69	4.12	3.77	3.75	3.36	3.75	3.30	3.00	2.50	3.00	3.00	3.00	2.38
5.75	...	...	4.62	4.35	4.50	4.19	4.12	3.77	3.75	3.36	3.75	3.30	3.00	2.50	3.00	3.00	3.00	2.38
6.00	...	...	4.62	4.35	4.50	4.19	4.62	4.27	4.50	4.12	3.75	3.30	4.00	3.50	3.00	3.00	3.00	2.38
6.25	...	...	5.12	4.85	5.00	4.69	4.62	4.27	4.50	4.12	4.50	4.04	4.00	3.50	4.00	3.44	3.00	2.38
6.50	...	...	...	...	5.00	4.69	5.12	4.77	4.50	4.12	4.50	4.04	4.00	3.50	4.00	3.44	4.00	3.38
6.75	...	...	...	...	5.50	5.19	5.12	4.77	5.25	4.86	4.50	4.04	4.00	3.50	4.00	3.44	4.00	3.38
7.00	...	...	...	...	5.50	5.19	5.62	5.27	5.25	4.86	5.25	4.80	5.00	4.50	4.00	3.44	4.00	3.38
7.25	...	...	...	...	6.00	5.69	5.62	5.27	5.25	4.86	5.25	4.80	5.00	4.50	4.00	3.44	4.00	3.38
7.50	...	...	...	...	6.00	5.69	6.12	5.77	6.00	5.62	5.25	4.80	5.00	4.50	4.00	3.44	5.00	4.38
7.75	...	...	...	...	...	...	6.12	5.77	6.00	5.62	6.00	5.54	5.00	4.50	5.00	4.44	5.00	4.38
8.00	...	...	...	...	...	...	6.62	6.27	6.00	5.62	6.30	5.54	5.00	4.50	5.00	4.44	5.00	4.38
8.50	...	...	...	...	...	...	7.12	6.77	7.00	6.62	6.75	6.30	6.00	5.50	6.00	5.44	6.00	5.38
9.00	...	...	...	...	...	...	7.62	7.27	7.00	6.62	6.75	6.30	7.00	6.50	6.00	5.44	6.00	5.38
9.50	...	...	...	...	...	...	...	...	8.00	7.62	7.75	7.30	7.00	6.50	6.00	5.44	7.00	6.38
10.00	...	...	...	...	...	...	...	...	8.00	7.62	7.75	7.30	8.00	7.50	7.00	6.44	7.00	6.38

**Table 4 Body and Grip Lengths for Socket Head Cap Screws (Cont'd)**

Nominal Size	1/4		5/16		3/8		7/16		1/2 and 9/16		5/8		3/4		7/8		1		
	$L_G$	$L_B$	$L_G$	$L_B$	$L_G$	$L_B$	$L_G$	$L_B$	$L_G$	$L_B$	$L_G$	$L_B$	$L_G$	$L_B$	$L_G$	$L_B$	$L_G$	$L_B$	
11.00	...	...	...	...	...	...	...	...	...	...	...	9.25	8.80	9.00	8.50	8.00	7.44	8.00	7.38
12.00	...	...	...	...	...	...	...	...	...	...	...	10.25	9.80	10.00	9.50	9.00	8.44	9.00	8.38
13.00	...	...	...	...	...	...	...	...	...	...	...	...	...	11.00	10.50	10.00	9.44	10.00	9.38
14.00	...	...	...	...	...	...	...	...	...	...	...	...	...	12.00	11.50	11.00	10.44	11.00	10.38
15.00	...	...	...	...	...	...	...	...	...	...	...	...	...	13.00	12.50	12.00	11.44	12.00	11.38
16.00	...	...	...	...	...	...	...	...	...	...	...	...	...	...	...	13.00	12.44	13.00	12.38
17.00	...	...	...	...	...	...	...	...	...	...	...	...	...	...	...	14.00	13.44	14.00	13.38
18.00	...	...	...	...	...	...	...	...	...	...	...	...	...	...	...	15.00	14.44	15.00	14.38
19.00	...	...	...	...	...	...	...	...	...	...	...	...	...	...	...	...	...	16.00	15.38
20.00	...	...	...	...	...	...	...	...	...	...	...	...	...	...	...	...	...	17.00	16.38

**GENERAL NOTES:**

- (a) The tabulated  $L_G$  values are maximum and represent the minimum design grip length of the screw. They shall be measured from the bearing surface of the head to the face of a GO thread ring gage, having the thread countersink and/or counterbore removed, which has been assembled by hand as far as the thread will permit. The tabulated  $L_B$  values are minimum and represent the minimum body length of the screw. They are equal to  $L_G$  minus 5 times the pitch of the UNRC thread for the respective screw size.
- (b) Screws having nominal lengths falling between those for which  $L_G$  and  $L_B$  values are tabulated in this Table shall have  $L_G$  and  $L_B$  dimensions conforming with those of the next shorter tabulated nominal length for the respective screw size. For example: for a 1/4 in. size screw,  $L_G = 0.50$  in. and  $L_B = 0.25$  in.
- (c) For screws of nominal lengths above the heavy bold line in this Table, the complete (full-form) threads, measured with a thread ring gage having the thread chamfer and/or counterbore removed, shall extend to within two pitches (threads) of the head for sizes 0 (0.060 in.) through 7/8 in., inclusive; and shall extend as close to the head as is practicable for sizes larger than 7/8 in.
- (d) Screws over 1 in. in diameter and of lengths shorter than the minimum thread length  $L_T$  plus 5 times the pitch of the UNRC thread for the respective screw size shall have complete (full-form) threads extending as close to the head as practicable. See (d) below for  $L_T$  values.
- (e) For screws of nominal lengths longer than those for which  $L_G$  and  $L_B$  values are tabulated in this Table and for screws over 1 in. in diameter, the maximum grip gaging length,  $L_G$ , and the minimum body length,  $L_B$ , of the screws shall be determined as shown in Table 5:

$$L_G = L - L_T$$

$$L_B = L - L_{TT}$$

where

- $L$  = nominal length
- $L_T$  = minimum thread length
- $L_{TT}$  = maximum total thread length

Table 4 Body and Grip Lengths for Socket Head Cap Screws (Cont'd)

Nominal Size	1/8		1/4		3/8		1/2	
	L <sub>G</sub>	L <sub>B</sub>	L <sub>G</sub>	L <sub>B</sub>	L <sub>G</sub>	L <sub>B</sub>	L <sub>G</sub>	L <sub>B</sub>
1.50	...	...	...	...	...	...	...	...
1.75	...	...	...	...	...	...	...	...
2.00	...	...	...	...	...	...	...	...
2.25	...	...	...	...	...	...	...	...
2.50	...	...	...	...	...	...	...	...
2.75	...	...	...	...	...	...	...	...
3.00	...	...	...	...	...	...	...	...
3.25	...	...	...	...	...	...	...	...
3.50	...	...	...	...	...	...	...	...
3.75	...	...	...	...	...	...	...	...
4.00	...	...	...	...	...	...	...	...
4.25	...	...	...	...	...	...	...	...
4.50	...	...	...	...	...	...	...	...
4.75	1.94	0.10	...	...	...	...	...	...
5.00	2.19	0.35	...	...	...	...	...	...
5.25	2.44	0.60	...	...	...	...	...	...
5.50	2.69	0.85	2.13	0.16	...	...	...	...
5.75	2.94	1.10	2.38	0.41	...	...	...	...
6.00	3.19	1.35	2.63	0.66	2.31	0.10	...	...
6.25	3.44	1.60	2.88	0.91	2.56	0.35	...	...
6.50	3.69	1.85	3.13	1.16	2.81	0.60	2.50	0.17
6.75	3.94	2.10	3.38	1.41	3.06	0.85	2.75	0.42
7.00	4.19	2.35	3.63	1.66	3.31	1.10	3.00	0.67
7.25	4.44	2.60	3.88	1.91	3.56	1.35	3.25	0.92
7.50	4.69	2.85	4.13	2.16	3.81	1.60	3.50	1.17
7.75	4.94	3.10	4.38	2.41	4.06	1.85	3.75	1.42
8.00	5.19	3.35	4.63	2.66	4.31	2.10	4.00	1.67
8.50	5.69	3.85	4.88	2.91	4.56	2.35	4.25	1.92
9.00	6.19	4.35	5.35	3.41	5.06	2.85	4.75	2.42
9.50	6.69	4.85	5.88	3.91	5.56	3.35	5.25	2.92
10.00	7.19	5.35	6.35	4.41	6.06	3.85	5.75	3.42
11.00	8.19	6.35	6.88	4.91	6.56	4.35	6.25	3.92
12.00	9.19	7.35	7.88	5.91	7.56	5.35	7.25	4.92
13.00	10.19	8.35	8.88	6.91	8.56	6.35	8.25	5.92
14.00	11.19	9.35	9.88	7.91	9.56	7.35	9.25	6.92
15.00	12.19	10.35	10.88	8.91	10.56	8.35	10.25	7.92
16.00	13.19	11.35	11.88	9.91	11.56	9.35	11.25	8.92
17.00	14.19	12.35	12.88	10.91	12.56	10.35	12.25	9.92
18.00	15.19	13.35	13.88	11.91	13.56	11.35	13.25	10.92
19.00	16.19	14.35	14.88	12.91	14.56	12.35	14.25	11.92
20.00	17.19	15.35	15.88	13.91	15.56	13.35	15.25	12.92
			16.88	14.91	16.56	14.35	16.25	13.92

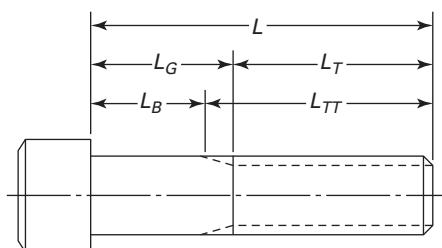
**Table 5 Lengths Beyond Sizes in Table 4**

Nominal Size (Basic Screw Diameter)	Minimum Thread Length, $L_T$	Maximum Total Thread Length, $L_{TT}$
0 (0.0600)	0.50	0.62
1 (0.0730)	0.62	0.77
2 (0.0860)	0.62	0.80
3 (0.0990)	0.62	0.83
4 (0.1120)	0.75	0.99
5 (0.1250)	0.75	1.00
6 (0.1380)	0.75	1.05
8 (0.1640)	0.88	1.19
10 (0.1900)	0.88	1.27
12 (0.2160)	0.88	1.27
$\frac{1}{4}$ (0.2500)	1.00	1.50
$\frac{5}{16}$ (0.3125)	1.12	1.71
$\frac{3}{8}$ (0.3750)	1.25	1.94
$\frac{7}{16}$ (0.4735)	1.38	2.17
$\frac{1}{2}$ (0.5000)	1.50	2.38
$\frac{9}{16}$ (0.5625)	1.50	2.38
$\frac{5}{8}$ (0.6250)	1.75	2.82
$\frac{3}{4}$ (0.7500)	2.00	3.25
$\frac{7}{8}$ (0.8750)	2.25	3.69
1 (1.0000)	2.50	4.12
$1\frac{1}{8}$ (1.1250)	2.81	4.65
$1\frac{1}{4}$ (1.2500)	3.12	5.09
$1\frac{3}{8}$ (1.3750)	3.44	5.65
$1\frac{1}{2}$ (1.5000)	3.75	6.08
$1\frac{3}{4}$ (1.7500)	4.38	7.13
2 (2.0000)	5.00	8.11
$2\frac{1}{4}$ (2.2500)	5.62	8.99
$2\frac{1}{2}$ (2.5000)	6.25	10.00
$2\frac{3}{4}$ (2.7500)	6.88	10.87
3 (3.0000)	7.50	11.75
$3\frac{1}{4}$ (3.2500)	8.12	12.63
$3\frac{1}{2}$ (3.5000)	8.75	13.50
$3\frac{3}{4}$ (3.7500)	9.38	14.37
4 (4.0000)	10.00	15.25

**Table 6 Shank Straightness for Socket Head Cap Screws**

Nominal Length	Nominal Size, $D_e$ Diameter [Note (1)]								
	0	1	2	3	4	5	6	8	10 and 12
Over 0 to 0.25, incl.	0.063	0.076	...	...	...	...	...	...	...
Over 0.25 to 0.50, incl.	0.065	0.078	...	...	...	...	...	...	...
Over 0.50 to 0.75, incl.	0.068	0.080	...	...	...	...	...	...	...
Over 0.75 to 1, incl.	0.070	0.082	...	...	...	...	...	...	...
Over 1 to 1.50, incl.	...	0.087	...	...	...	...	...	...	...
Over 0 to 0.50, incl.	...	...	0.090	0.103	0.116	...	...	...	...
Over 0.50 to 1, incl.	...	...	0.095	0.107	0.120	...	...	...	...
Over 1 to 1.50, incl.	...	...	0.099	0.111	0.123	...	...	...	...
Over 1.50 to 2, incl.	...	...	0.103	0.115	0.127	...	...	...	...
Over 2 to 2.50, incl.	...	...	...	...	0.131	...	...	...	...
Over 0 to 0.75, incl.	...	...	...	...	...	0.130	0.143	0.168	...
Over 0.75 to 1.50, incl.	...	...	...	...	...	0.136	0.148	0.173	...
Over 1.50 to 2.25, incl.	...	...	...	...	...	0.140	0.153	0.178	...
Over 2.25 to 3, incl.	...	...	...	...	...	0.146	0.158	0.183	...
Over 3 to 4, incl.	...	...	...	...	...	0.150	0.163	0.189	...
Over 0 to 1, incl.	...	...	...	...	...	...	...	...	0.196
Over 1 to 2, incl.	...	...	...	...	...	...	...	...	0.201
Over 2 to 3, incl.	...	...	...	...	...	...	...	...	0.207
Over 3 to 4, incl.	...	...	...	...	...	...	...	...	0.213
Over 4 to 6, incl.	...	...	...	...	...	...	...	...	0.215

Nominal Length	Nominal Size, $D_e$ Diameter [Note (1)]								
	$\frac{1}{4}$	$\frac{5}{16}$	$\frac{3}{8}$	$\frac{7}{16}$	$\frac{1}{2}$ and $\frac{9}{16}$	$\frac{5}{8}$	$\frac{3}{4}$	$\frac{7}{8}$	1
Over 0 to 1, incl.	0.255	0.317	0.379	0.441	...	...	...	...	...
Over 1 to 2, incl.	0.260	0.322	0.383	0.445	...	...	...	...	...
Over 2 to 3, incl.	0.265	0.326	0.387	0.449	...	...	...	...	...
Over 3 to 4, incl.	0.270	0.331	0.391	0.453	...	...	...	...	...
Over 4 to 6, incl.	0.275	0.337	0.400	0.462	...	...	...	...	...
Over 0 to 2, incl.	...	...	...	...	0.507	0.631	0.756	0.880	1.005
Over 2 to 4, incl.	...	...	...	...	0.514	0.638	0.762	0.886	1.010
Over 4 to 6, incl.	...	...	...	...	0.521	0.644	0.767	0.891	1.015
Over 6 to 8, incl.	...	...	...	...	0.525	0.650	0.773	0.897	1.020
Over 8 to 10, incl.	...	...	...	...	...	...	0.775	0.900	1.025

Nominal Length	Nominal Size, $D_e$ Diameter [Note (1)]						
	$1\frac{1}{8}$	$1\frac{1}{4}$	$1\frac{3}{8}$	$1\frac{1}{2}$	$1\frac{3}{4}$	2	$2\frac{1}{4}$
Over 0 to 6, incl.	1.140	1.265	1.390	1.515	1.765	2.015	2.265
Over 6 to 12, incl.	1.155	1.280	1.405	1.530	1.780	2.030	2.280
Over 12 to 18, incl.	1.170	1.295	1.420	1.545	1.795	2.045	2.295
Over 18 to 24, incl.	1.185	1.310	1.435	1.560	1.810	2.060	2.310

Nominal Length	Nominal Size, $D_e$ Diameter [Note (1)]						
	$2\frac{1}{2}$	$2\frac{3}{4}$	3	$3\frac{1}{4}$	$3\frac{1}{2}$	$3\frac{3}{4}$	4
Over 0 to 6, incl.	2.515	2.765	3.015	3.265	3.515	3.765	4.015
Over 6 to 12, incl.	2.530	2.780	3.030	3.280	3.530	3.780	4.030
Over 12 to 18, incl.	2.545	2.795	3.045	3.295	3.545	3.795	4.045
Over 18 to 24, incl.	2.560	2.810	3.060	3.310	3.560	3.810	4.060

## NOTE:

- (1) The largest diameter,  $D_e$ , specified for the various screw sizes shall apply for any nominal screw length longer than that tabulated for the respective nominal screw size. For  $D_e$  diameters, see Mandatory Appendix III.

**Table 7 Dimensions of Drilled Hexagon Socket Head Cap Screws**

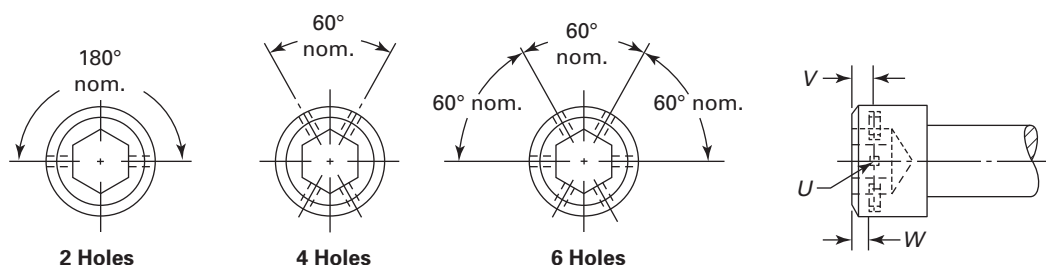
Nominal Size (Basic Screw Diameter) [Note (1)]	Drilled Hole Diameter, <i>U</i> [Notes (2) and (3)]		Head to Center of Hole, <i>V</i>		Minimum Head to Edge of Hole, <i>W</i>	Drill Check Plug, Diameter, Basic [Note (3)]		Hole Alignment Check Plug Diameter [Note (3)]	Min. Torque Value, ft-lb [Note (4)]
	Number	Basic	Max.	Min.		Type I	Type II		
4 (0.1120)	65	0.0350	0.040	0.026	0.008	0.030	0.033	0.025	1.5
5 (0.1250)	65	0.0350	0.045	0.030	0.012	0.030	0.033	0.025	2
6 (0.1380)	65	0.0350	0.050	0.035	0.018	0.030	0.033	0.025	3
8 (0.1640)	56	0.0465	0.060	0.040	...	0.035	0.044	0.030	5
10 (0.1900)	56	0.0465	0.065	0.045	...	0.035	0.044	0.030	8
12 (0.2160)	56	0.0465	0.065	0.045	...	0.035	0.044	0.030	11
1/4 (0.2500)	56	0.0465	0.085	0.065	...	0.035	0.044	0.030	18
5/16 (0.3125)	56	0.0465	0.104	0.084	...	0.035	0.044	0.030	37
3/8 (0.3750)	52	0.0635	0.123	0.103	...	0.052	0.061	0.047	67
7/16 (0.4375)	52	0.0635	0.141	0.121	...	0.052	0.061	0.047	102
1/2 (0.5000)	52	0.0635	0.160	0.140	...	0.052	0.061	0.047	162
9/16 (0.5625)	52	0.0635	0.160	0.140	...	0.052	0.061	0.047	218
5/8 (0.6250)	52	0.0635	0.198	0.178	...	0.052	0.061	0.047	306
3/4 (0.7500)	42	0.0935	0.235	0.215	...	0.082	0.091	0.077	535
7/8 (0.8750)	42	0.0935	0.273	0.253	...	0.082	0.091	0.077	852
1 (1.0000)	42	0.0935	0.310	0.290	...	0.082	0.091	0.077	1,267
1 1/8 (1.1250)	31	0.1200	0.348	0.328	...	0.109	0.117	0.104	1,840
1 1/4 (1.2500)	31	0.1200	0.385	0.365	...	0.109	0.117	0.104	2,564
1 3/8 (1.3750)	31	0.1200	0.423	0.403	...	0.109	0.117	0.104	3,443
1 1/2 (1.5000)	31	0.1200	0.460	0.440	...	0.109	0.117	0.104	4,534

GENERAL NOTE: Drilled hexagon socket head cap screws frequently experience premature stripping of the recessed drive during installation. For additional requirements, refer to Notes (4) and (5) and also section 2 of this Standard.

NOTES:

- (1) *Nominal Size*. Where specifying nominal size in decimals, zeros preceding decimal and in the fourth decimal place shall be omitted.
- (2) *Number of Holes*. Screws shall have 2, 4, or 6 holes drilled in the head as designated by the purchaser. For sizes 10 (0.190 in.) and smaller, the use of only 2 holes is recommended.
- (3) *Holes*. Hole size and location from the top of the head shall conform to the specifications given in this Table. For sizes 1/4 in. (0.250 in.) and larger, the drilled hole shall lie within the flats of the hexagon socket and not break through the socket corners. Positioning of holes on opposite sides of the socket shall be such that the hole alignment check plug will pass completely through the head on all screw sizes.

For commercial-quality screws, the edge of the holes on the outside of the head may be chamfered or broken. The edge of the holes within the socket may contain burrs to the extent that the socket will accept a key having the standard minimum width across the flats (see Table 17) and the holes must allow the Type I drill check plug to pass from the outside of the head into the socket.

For aircraft-quality screws, the edge of the holes on the outside of the head shall be chamfered and there shall be no burr chips or slivers that might become dislodged during usage. The socket shall accept a key having the standard maximum width across the flats (see Table 17) and the hole must allow the Type II drill check plug to pass from the outside of the head into the socket.

Chamfer on the edge of the holes, whether provided optionally or as required, shall be subject to visual inspection only.



**Table 7 Dimensions of Drilled Hexagon Socket Head Cap Screws (Cont'd)**

- (4) *Screws.* Drilled hexagon socket head cap screws shall conform to the respective dimensions and requirements set forth in Table 1 and the notes thereto, except for the holes in the head as specified in this Table and Notes (2) and (3). Drilled sockets must withstand torque applied using a new bit or key equal to  $T = KDP$ , where  $T$  is torque expressed in inch-pounds,  $D$  is the nominal diameter,  $K$  is 0.20, and  $P$  is equal to 75% of the screw material's yield strength times the tensile stress area. Divide this value by 12 to express torque in foot-pounds. The minimum torque value shall be determined by seating the screw in a nut or threaded test plate using enough carbon steel hardened washers (HRC 35 minimum) to provide a thickness greater than the allowable under head radius size.
- (5) *Designation.* To promote uniformity and understanding in communications relating to products conforming to this Standard, it is recommended that drilled hexagon socket head cap screws be designated in accordance with the following data, preferably in the sequence shown:
- (a) product name, including number of holes
  - (b) designation of the standard
  - (c) nominal size (number, fractional, or decimal equivalent)
  - (d) thread pitch
  - (e) nominal length (fractional or decimal equivalent)
  - (f) material
  - (g) protective finish, if required

## EXAMPLE:

Drilled (2 holes) Hexagon Socket Head Cap Screws, ASME B18.3, 6-32  $\times$   $\frac{3}{4}$ , Alloy Steel

For the recommended B18 part identifying numbering system (PIN), see ASME B18.24.

FINESZ 泛微

**Table 8 Dimensions of Hexagon Socket Flat Countersunk Head Cap Screws**

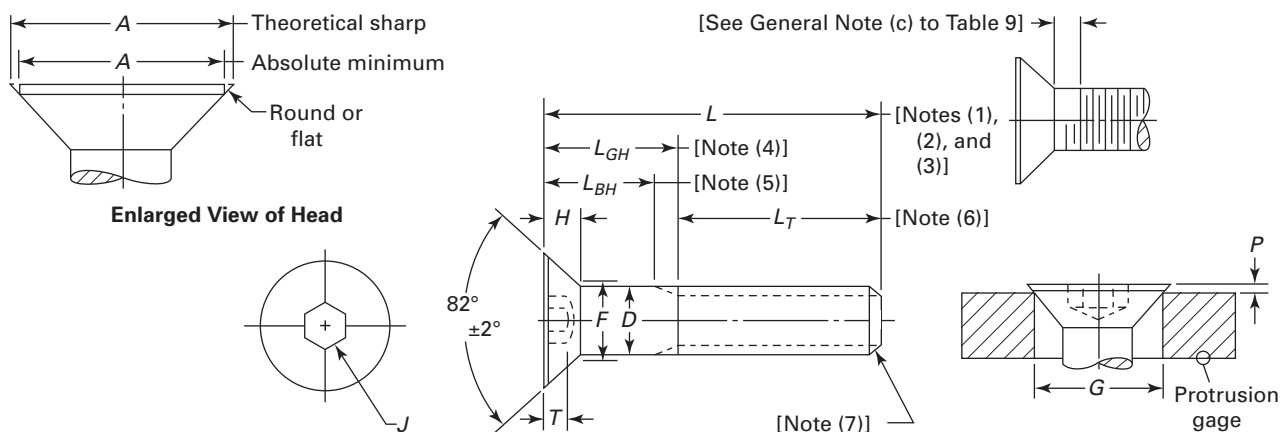

Nominal Size (Basic Screw Diameter)	Body Diameter, <i>D</i>		Head Diameter, <i>A</i>		Reference Head Height, <i>H</i>	Protrusion Gage Diameter, <i>G</i>		Protrusion, <i>P</i>		Nominal Hexagon Socket Size, <i>J</i>	Minimum Key Engage- ment, <i>T</i>	Maximum Fillet Transition Diameter, <i>F</i>	
	Max.	Min.	Max.	Min.		Max.	Min.	Max.	Min.				
0 (0.0600)	0.0600	0.0568	0.138	0.117	0.044	0.078	0.077	0.044	0.026	...	0.035	0.025	0.072
1 (0.0730)	0.0730	0.0695	0.168	0.143	0.054	0.101	0.100	0.048	0.028	...	0.050	0.031	0.089
2 (0.0860)	0.0860	0.0822	0.197	0.168	0.064	0.124	0.123	0.051	0.031	...	0.050	0.038	0.106
3 (0.0990)	0.0990	0.0949	0.226	0.193	0.073	0.148	0.147	0.054	0.033	1/16	0.062	0.044	0.119
4 (0.1120)	0.1120	0.1075	0.255	0.218	0.083	0.172	0.171	0.057	0.036	1/16	0.062	0.055	0.136
5 (0.1250)	0.1250	0.1202	0.281	0.240	0.090	0.196	0.195	0.059	0.037	5/64	0.078	0.061	0.153
6 (0.1380)	0.1380	0.1329	0.307	0.263	0.097	0.220	0.219	0.060	0.037	5/64	0.078	0.066	0.168
8 (0.1640)	0.1640	0.1585	0.359	0.311	0.112	0.267	0.266	0.063	0.039	3/32	0.094	0.076	0.194
10 (0.1900)	0.1900	0.1840	0.411	0.359	0.127	0.313	0.312	0.066	0.041	1/8	0.125	0.087	0.220
12 (0.2158)	0.2158	0.2102	0.450	0.410	0.135	0.360	0.359	0.069	0.042	1/8	0.125	0.094	0.246
1/4 (0.2500)	0.2500	0.2435	0.531	0.480	0.161	0.424	0.423	0.072	0.043	5/32	0.156	0.111	0.280
5/16 (0.3125)	0.3125	0.3053	0.656	0.600	0.198	0.539	0.538	0.078	0.047	3/16	0.188	0.135	0.343
3/8 (0.3750)	0.3750	0.3678	0.781	0.720	0.234	0.653	0.652	0.088	0.050	7/32	0.219	0.159	0.405
7/16 (0.4375)	0.4375	0.4294	0.844	0.781	0.234	0.690	0.689	0.104	0.063	1/4	0.250	0.159	0.468
1/2 (0.5000)	0.5000	0.4919	0.938	0.872	0.251	0.739	0.738	0.131	0.087	5/16	0.312	0.172	0.530
5/8 (0.6250)	0.6250	0.6163	1.188	1.112	0.324	0.962	0.961	0.146	0.096	3/8	0.375	0.220	0.655
3/4 (0.7500)	0.7500	0.7406	1.438	1.355	0.396	1.186	1.185	0.170	0.105	1/2	0.500	0.220	0.780
7/8 (0.8750)	0.8750	0.8647	1.688	1.604	0.468	1.411	1.410	0.165	0.118	9/16	0.562	0.248	0.905
1 (1.0000)	1.0000	0.9886	1.938	1.841	0.540	1.635	1.634	0.181	0.130	5/8	0.625	0.297	1.030
1 1/8 (1.1250)	1.1250	1.1086	2.188	2.079	0.611	1.859	1.858	0.196	0.140	3/4	0.750	0.325	1.187
1 1/4 (1.2500)	1.2500	1.2336	2.438	2.316	0.683	2.083	2.082	0.212	0.150	7/8	0.875	0.358	1.312
1 3/8 (1.3750)	1.3750	1.3568	2.688	2.553	0.755	2.306	2.305	0.228	0.162	7/8	0.875	0.402	1.437
1 1/2 (1.5000)	1.5000	1.4818	2.938	2.791	0.827	2.530	2.529	0.243	0.173	1	1.000	0.435	1.562

GENERAL NOTE: For additional requirements, refer to Notes (8) through (19) and section 2, General Data, of this Standard.

**Table 8 Dimensions of Hexagon Socket Flat Countersunk Head Cap Screws (Cont'd)**

## NOTES:

- (1) *Length*. The length of the screw shall be measured, parallel to the axis of the screw, from the plane of the top of the head to the plane of the flat of the point. The basic length dimension on the product shall be the nominal length expressed as a two-placed decimal.
- (2) *Standard Lengths*. Standard length increments for socket flat countersunk head cap screws shall be as tabulated below.

Nominal Screw Size	Nominal Screw Length	Standard Length Increment
0 to 1.00, incl.	0.13 through 0.25	0.06
	0.25 through 1.00	0.13
	1.00 through 3.50	0.25
	3.50 through 7.00	0.50
	7.00 through 10.00	1.00
Over 1.00	1.00 through 7.00	0.50
	7.00 through 10.00	1.00
	Over 10.00	2.00

- (3) *Length Tolerances*. The allowable tolerance on length shall be as tabulated below.

Nominal Screw Length	Nominal Screw Size, Tolerances on Length		
	0 Through $\frac{3}{8}$ , Incl.	$\frac{7}{16}$ Through $\frac{3}{4}$ , Incl.	$\frac{7}{8}$ Through $1\frac{1}{2}$ , Incl.
Up to 1.00, incl.	-0.03	-0.03	-0.05
Over 1.00 to 2.50, incl.	-0.04	-0.06	-0.10
Over 2.5 to 6.00, incl.	-0.06	-0.08	-0.14
Over 6.00	-0.12	-0.12	-0.20

- (4) *Grip Gaging Length,  $L_{GH}$* . Grip gaging length is the distance, measured parallel to the axis of the screw, from the top of the head to the first complete (full-form) thread under the head (see Table 10).
- (5) *Body Length,  $L_{BH}$* . Body length is the length, measured parallel to the axis of the screw, of the unthreaded portion of the shank and the head height (see Table 10).
- (6) *Thread Length  $L_T$* . The length of the thread shall be measured, parallel to the axis of the screw, from the extreme point to the last complete (full-form) thread. Thread length, on socket flat countersunk head cap screws, shall be as defined by Table 9 and notes thereto.
- (7) *Screw Point Chamfer*. The point shall be flat or slightly concave and chamfered. The plane of the point shall be approximately normal to the axis of the screw. The chamfer shall extend slightly below the root of the thread, and the edge between the flat and chamfer may be slightly rounded. The included angle of the point should be approximately 90 deg. Chamfering of the screw sizes up to and including size 8 (0.164 in.) and lengths below  $1.5d$  shall be optional.
- (8) *Nominal Size*. Where specifying nominal size in decimals, zeros preceding decimal and in the fourth decimal place shall be omitted.
- (9) *Body*. The term *body* refers to the unthreaded cylindrical portion of the shank for those screws not threaded to the head.
- (10) *Fillet*. A fillet between the conical bearing surface of the head and the shank (body) of the screw is allowable to the maximum  $F$  value (Table 8).
- (11) *Head Diameter*. Maximum sharp values under column A are theoretical values only, as it is not practical to make the edges of the head sharp. The maximum sharp value represents the exact diameter of the hole countersunk to exactly 82 deg, in which a screw having maximum head size will fit flush.
- (12) *Head Height*. Tabulated values for head height are given for reference only and are calculated to the maximum formulation.
- (13) *Protrusion*. Suitability of socket flat countersunk head cap screws for application in countersinks designed to the principal dimensions of the screws shall be determined by use of a protrusion gage. The protrusion limits shown shall apply only when the gaging diameter is exactly as indicated with the gaging edge of a sharpness obtained by lapping the hole and the top surface of the gage. The top of the head shall be flat within the limits of the protrusion tolerance. See Mandatory Appendix II for gaging details.
- (14) See Table 18 for hexagon socket dimensions and Mandatory Appendix I for gaging of hexagon sockets.

**Table 8 Dimensions of Hexagon Socket Flat Countersunk Head Cap Screws (Cont'd)**

- (15) *Bearing Surface.* The runout of the conical bearing surface shall be within 1 deg obtained by holding the screw on the body or major screw thread diameter within 1 diameter of the bearing surface of the head, but beyond the maximum length of the fillet,  $F$ , rotating 360 deg and inspecting on an optical comparator, or comparable inspection equipment.
- (16) *Runout*
- (a) The runout of the socket with the axis of the shank of the screw shall be within 3% of the maximum screw diameter,  $D$ , or 0.005 in., whichever is greater for nominal sizes through  $\frac{1}{2}$  in. diameter and 6% for nominal sizes above  $\frac{1}{2}$  in. diameter. Runout for (a) above is defined as the full indicator movement (FIM) obtained by holding the screw on the body or major thread diameter within 1 diameter of the bearing surface of the head, but beyond the maximum length of the fillet,  $F$ , rotating 360 deg, indicating on each of the six hexagon flats.
- (b) The conformance of screws to shank straightness or camber limitations shall be as set forth as  $D_e$  in Table 6 (Socket Head Cap Screws), and shall be checked by the use of the procedures and typical gage illustrated in ASME B18.2.9.
- (17) *Threads.* Threads shall be Unified external threads with radius root: Class 3A UNRC and UNRF Series for sizes 0 (0.060 in.) through 1 in.; Class 2A UNRC and UNRF Series for sizes over 1 in. to  $1\frac{1}{2}$  in., inclusive. Acceptability shall be based on System 22, ASME B1.3. Class 3A does not provide a plating allowance.
- (18) *Material*
- (a) *Steel, Alloy.* Flat countersunk head cap screws shall be fabricated from an alloy steel and shall conform in all respects to ASTM F835.
- (b) *Steel, Corrosion-Resistant.* Flat countersunk head cap screws shall be fabricated from austenitic corrosion-resistant steel and shall conform in all respects to ASTM F879.
- (19) *Designation.* To promote uniformity and understanding in communications relating to products conforming to this Standard, it is recommended that Hexagon Flat Countersunk Socket Head Cap Screws be designated in accordance with the following data, preferably in the sequence shown:
- (a) product name  
 (b) designation of the standard  
 (c) nominal size (number, fractional or decimal equivalent)  
 (d) thread pitch  
 (e) nominal length (fractional or decimal equivalent)  
 (f) material (for corrosion resistant steel, specify alloy group and condition)  
 (g) protective finish, if required

**EXAMPLES:**Hexagon Socket Flat Countersunk Head Cap Screws, ASME B18.3,  $\frac{1}{4}$ -28  $\times$   $1\frac{3}{4}$ , Alloy SteelHexagon Socket Flat Countersunk Head Cap Screws, ASME B18.3, 0.250-28  $\times$  1.750, Alloy group 1, condition CW per ASTM F879.

For the recommended B18 part identifying numbering system (PIN), see ASME B18.24.

Table 9 Body and Grip Lengths for Socket Flat Countersunk Head Cap Screws

Nominal Size	0		1		2		3		4		5		6		8		10	
	$L_{GH}$	$L_{BH}$	$L_{GH}$	$L_{BH}$	$L_{GH}$	$L_{BH}$	$L_{GH}$	$L_{BH}$	$L_{GH}$	$L_{BH}$	$L_{GH}$	$L_{BH}$	$L_{GH}$	$L_{BH}$	$L_{GH}$	$L_{BH}$	$L_{GH}$	$L_{BH}$
0.75	0.25	0.19	...	...	...	...	...	...	...	...	...	...	...	...	...	...	...	...
0.88	0.25	0.19	0.25	0.17	0.25	0.16	0.25	0.25	0.15	...	...	...	...	...	...	...	...	...
1.00	0.50	0.44	0.25	0.17	0.25	0.16	0.25	0.15	...	...	...	...	...	...	...	...	...	...
1.25	0.75	0.69	0.62	0.55	0.62	0.54	0.62	0.52	0.50	0.38	0.50	0.38	0.50	0.34	0.38	0.22	0.62	0.42
1.50	...	...	0.88	0.80	0.88	0.79	0.88	0.77	0.50	0.38	0.50	0.38	0.50	0.34	0.38	0.22	0.62	0.42
1.75	...	...	...	...	1.12	1.04	1.12	1.02	1.00	0.88	1.00	0.88	1.00	0.84	0.88	0.72	0.62	0.42
2.00	...	...	...	...	1.38	...	1.38	1.27	1.00	0.88	1.00	0.88	1.00	0.84	0.88	0.72	1.12	0.92
2.25	...	...	...	...	...	...	...	...	1.50	1.38	1.50	1.38	1.50	1.34	1.38	1.22	1.12	0.92
2.50	...	...	...	...	...	...	...	...	...	...	...	...	1.50	1.34	1.38	1.22	1.62	1.42
2.75	...	...	...	...	...	...	...	...	...	...	...	...	2.00	1.84	1.72	1.62	1.62	1.42
3.00	...	...	...	...	...	...	...	...	...	...	...	...	...	...	1.88	1.72	2.12	1.92
3.25	...	...	...	...	...	...	...	...	...	...	...	...	...	...	2.38	2.22	2.12	1.92
3.50	...	...	...	...	...	...	...	...	...	...	...	...	...	...	...	...	2.62	2.42
3.75	...	...	...	...	...	...	...	...	...	...	...	...	...	...	...	...	2.62	2.42
4.00	...	...	...	...	...	...	...	...	...	...	...	...	...	...	...	...	3.12	2.92

**Table 9 Body and Grip Lengths for Socket Flat Countersunk Head Cap Screws (Cont'd)**

Nominal Size	1/4		5/16		3/8		1/2		5/8		3/4		7/8		1	
	L <sub>GH</sub>	L <sub>BH</sub>	L <sub>GH</sub>	L <sub>BH</sub>	L <sub>GH</sub>	L <sub>BH</sub>	L <sub>GH</sub>	L <sub>BH</sub>	L <sub>GH</sub>	L <sub>BH</sub>	L <sub>GH</sub>	L <sub>BH</sub>	L <sub>GH</sub>	L <sub>BH</sub>	L <sub>GH</sub>	L <sub>BH</sub>
1.75	0.75	0.50	...	...	...	...	...	...	...	...	...	...	...	...	...	...
2.00	0.75	0.50	0.88	0.60	...	...	...	...	...	...	...	...	...	...	...	...
2.25	1.25	1.00	0.88	0.60	1.00	0.69	...	...	...	...	...	...	...	...	...	...
2.50	1.25	1.00	1.38	1.10	1.00	0.69	1.12	0.77	1.00	0.62	...	...	...	...	...	...
2.75	1.75	1.50	1.38	1.10	1.50	1.19	1.12	0.77	1.00	0.62	...	...	...	...	...	...
3.00	1.75	1.50	1.88	1.60	1.50	1.19	1.62	1.27	1.00	0.62	...	...	...	...	...	...
3.25	2.25	2.00	1.88	1.60	2.00	1.69	1.62	1.27	1.75	1.36	1.50	1.04	...	...	...	...
3.50	2.25	2.00	2.38	2.10	2.00	1.69	2.12	1.77	1.75	1.36	1.50	1.04	1.50	1.00	...	...
3.75	2.75	2.50	2.38	2.10	2.50	2.19	2.12	1.77	1.75	1.36	1.50	1.04	1.50	1.00	1.50	0.94
4.00	2.75	2.50	2.88	2.60	2.50	2.19	2.62	2.27	2.50	2.12	2.25	1.80	1.50	1.00	1.50	0.88
4.25	3.25	3.00	2.88	2.60	3.00	2.69	2.62	2.27	2.50	2.12	2.25	1.80	1.50	1.00	1.50	0.88
4.50	3.25	3.00	3.38	3.10	3.00	2.69	3.12	2.77	2.50	2.12	2.25	1.80	1.50	1.00	1.50	0.88
4.75	3.75	3.50	3.38	3.10	3.50	3.19	3.12	2.77	3.25	2.86	3.00	2.54	2.50	2.00	2.50	1.88
5.00	3.75	3.50	3.88	3.60	3.50	3.19	3.62	3.27	3.25	2.86	3.00	2.54	2.50	2.00	2.50	1.88
5.25	4.25	4.00	3.88	3.60	4.00	3.69	3.62	3.27	3.25	2.86	3.00	2.54	2.50	2.00	2.50	1.88
5.50	...	...	4.38	4.10	4.00	3.69	4.12	3.77	4.00	3.62	3.75	3.30	3.50	3.00	2.50	1.88
5.75	...	...	4.38	4.10	4.50	4.19	4.12	3.77	4.00	3.62	3.75	3.30	3.50	3.00	2.50	1.88
6.00	...	...	4.88	4.60	4.50	4.19	4.62	4.27	4.00	3.62	3.75	3.30	3.50	3.00	2.50	1.88
6.25	...	...	4.88	4.60	5.00	4.69	4.62	4.27	4.75	4.36	4.50	4.04	3.50	3.00	2.50	1.88
6.50	...	...	5.38	5.10	5.00	4.69	5.12	4.77	4.75	4.36	4.50	4.04	3.50	3.00	2.50	1.88
6.75	...	...	...	...	5.50	5.19	5.12	4.77	4.75	4.36	4.50	4.04	4.50	4.00	3.50	2.88
7.00	...	...	...	...	5.50	5.19	5.62	5.27	5.50	5.12	5.25	4.80	4.50	4.00	3.50	3.88
7.25	...	...	...	...	6.00	5.69	5.62	5.27	5.50	5.12	5.25	4.80	4.50	4.00	3.50	3.88
7.50	...	...	...	...	6.00	5.69	6.12	5.77	5.50	5.12	5.25	4.80	4.50	4.00	3.50	3.88
7.75	...	...	...	...	6.50	6.19	6.12	5.77	6.25	5.86	6.00	5.54	5.50	5.00	4.50	3.88
8.00	...	...	...	...	...	...	6.62	6.27	6.25	5.86	6.00	5.54	5.50	5.00	4.50	4.88
8.50	...	...	...	...	...	...	7.12	6.77	7.00	6.62	6.75	6.30	6.50	6.00	5.50	4.88
9.00	...	...	...	...	...	...	7.62	7.27	7.00	7.00	6.75	6.30	6.50	6.00	5.50	4.88
9.50	...	...	...	...	...	...	8.12	7.77	8.00	7.62	7.75	7.30	7.50	7.00	6.50	5.88
10.00	...	...	...	...	...	...	...	...	8.00	7.62	7.75	7.30	7.50	7.00	6.50	5.88

**Table 9 Body and Grip Lengths for Socket Flat Countersunk Head Cap Screws (Cont'd)**

Nominal Size	1/4		5/16		3/8		7/16		1/2		5/8		3/4		7/8		1	
	$L_{GH}$	$L_{BH}$	$L_{GH}$	$L_{BH}$	$L_{GH}$	$L_{BH}$	$L_{GH}$	$L_{BH}$	$L_{GH}$	$L_{BH}$	$L_{GH}$	$L_{BH}$	$L_{GH}$	$L_{BH}$	$L_{GH}$	$L_{BH}$	$L_{GH}$	$L_{BH}$
11.00	...	...	...	...	...	...	...	...	...	...	9.25	8.80	9.00	8.50	8.75	8.19	8.50	7.88
12.00	...	...	...	...	...	...	...	...	...	...	10.25	9.80	10.00	9.50	9.75	9.19	9.50	8.88
13.00	...	...	...	...	...	...	...	...	...	...	...	...	11.00	10.50	10.75	10.19	10.50	9.88
14.00	...	...	...	...	...	...	...	...	...	...	...	...	12.00	11.50	11.75	11.19	11.50	10.88
15.00	...	...	...	...	...	...	...	...	...	...	...	...	13.00	12.50	12.75	12.19	12.50	11.88
16.00	...	...	...	...	...	...	...	...	...	...	...	...	...	...	13.75	13.19	13.50	12.88
17.00	...	...	...	...	...	...	...	...	...	...	...	...	...	...	14.75	14.19	14.50	13.88
18.00	...	...	...	...	...	...	...	...	...	...	...	...	...	...	15.75	15.19	15.50	14.88
19.00	...	...	...	...	...	...	...	...	...	...	...	...	...	...	...	...	16.50	15.88
20.00	...	...	...	...	...	...	...	...	...	...	...	...	...	...	...	...	17.50	16.88

**GENERAL NOTES:**

- (a) Tabulated  $L_{GH}$  values are maximum and represent the minimum design grip length, including the reference head height of the screw. They shall be measured from the top of the head to the face of a GO thread ring gage, having the thread countersink and/or counterbore removed, which has been assembled by hand as far as the thread will permit. The tabulated  $L_{BH}$  values are minimum and represent the minimum body length, including the reference head height of the screw. They are equal to  $L_{GH}$  minus 5 times the pitch of the UNRC thread for the respective screw size.
- (b) Screws having nominal lengths falling between those for which  $L_{GH}$  and  $L_{BH}$  values are tabulated in this Table shall have  $L_{GH}$  and  $L_{BH}$  dimensions conforming with those of the next shorter tabulated nominal length for the respective screw size. For example: for a 1/4 in. size screw, 2.13 in. long,  $L_{GH} = 0.75$  in. and  $L_{BH} = 0.50$  in.
- (c) For screws of nominal lengths above the heavy bold line in this Table, the complete (full-form) threads, measured with a thread ring gage having the thread chamfer and/or counterbore removed, shall extend to within two pitches (threads) of the intersection of the conical portion of the head with the basic screw diameter.  
Screws over 1 in. in diameter and of lengths shorter than the minimum thread length,  $L_T$ , plus 5 times the pitch of the UNRC thread for the respective screw size shall have complete (full-form) threads extending as close to the head as practicable. See General Note (d) for  $L_T$  values.
- (d) For screws of nominal lengths longer than those for which  $L_{GH}$  and  $L_{BH}$  values are tabulated in this Table and for screws over 1 in. in diameter, the maximum grip gaging length,  $L_{GH}$ , and the minimum body length,  $L_{BH}$ , of the screws shall be determined as shown in Table 10:

$$L_{GH} = L - L_T$$

$$L_{BH} = L - L_{TT}$$

where

- $L$  = nominal length
- $L_T$  = minimum thread length
- $L_{TT}$  = maximum total thread length

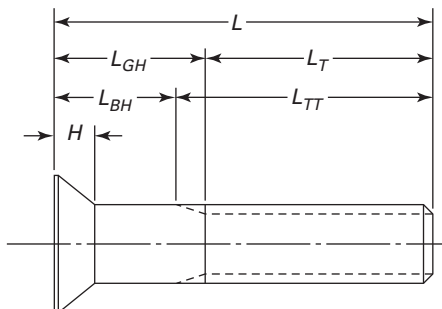
**Table 10 Lengths Beyond Sizes in Table 9**

Nominal Size (Basic Screw Diameter)	Minimum Thread Length, $L_T$	Maximum Total Thread Length, $L_{TT}$
0 (0.0600)	0.50	0.62
1 (0.0730)	0.62	0.77
2 (0.0860)	0.62	0.80
3 (0.0990)	0.62	0.93
4 (0.1120)	0.75	0.99
5 (0.1250)	0.75	1.00
6 (0.1380)	0.75	1.05
8 (0.1640)	0.88	1.19
10 (0.1900)	0.88	1.27
12 (0.2160)	0.88	1.27
$\frac{1}{4}$ (0.2500)	1.00	1.50
$\frac{5}{16}$ (0.3125)	1.12	1.71
$\frac{3}{8}$ (0.3750)	1.25	1.94
$\frac{7}{16}$ (0.4375)	1.38	2.17
$\frac{1}{2}$ (0.5000)	1.50	2.38
$\frac{5}{8}$ (0.6250)	1.75	2.82
$\frac{3}{4}$ (0.7500)	2.00	3.25
$\frac{7}{8}$ (0.8750)	2.25	3.69
1 (1.0000)	2.50	4.12
$1\frac{1}{8}$ (1.1250)	2.81	4.65
$1\frac{1}{4}$ (1.2500)	3.12	5.09
$1\frac{3}{8}$ (1.3750)	3.44	5.65
$1\frac{1}{2}$ (1.5000)	3.75	6.08



**Table 11 Dimensions of Hexagon Socket Button Head Cap Screws**

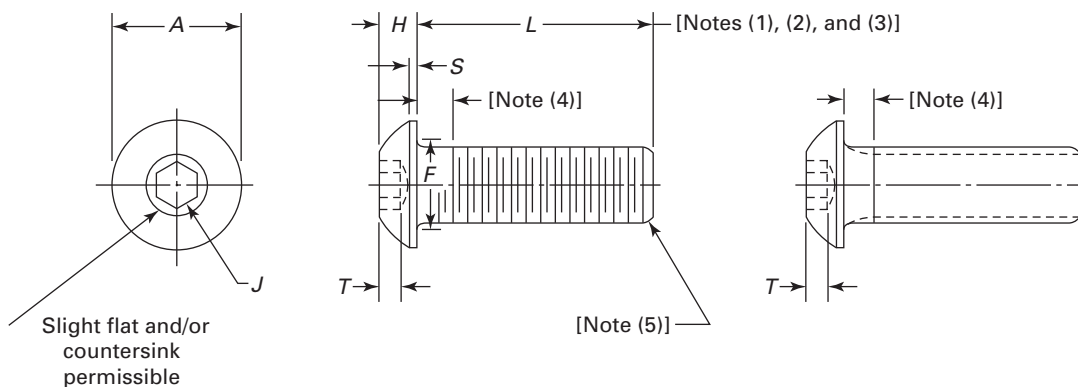

Nominal Size (Basic Screw Diameter)	Head Diameter, <i>A</i>		Head Height, <i>H</i>		Head Side Height, <i>S</i> (Ref.)	Nominal Hexagon Socket Size, <i>J</i>	Minimum Key Engagement, <i>T</i>	Fillet Extension, <i>F</i>		Nominal Maximum Standard Length, <i>L</i>	
	Max.	Min.	Max.	Min.				Max.	Min.		
0 (0.0600)	0.114	0.104	0.032	0.026	0.010	...	0.035	0.020	0.080	0.070	0.50
1 (0.0730)	0.139	0.129	0.039	0.033	0.010	...	0.050	0.028	0.093	0.083	0.50
2 (0.0860)	0.164	0.154	0.046	0.038	0.010	...	0.050	0.028	0.106	0.096	0.50
3 (0.0990)	0.188	0.176	0.052	0.044	0.010	1/16	0.062	0.035	0.119	0.109	0.50
4 (0.1120)	0.213	0.201	0.059	0.051	0.015	1/16	0.062	0.035	0.132	0.122	0.50
5 (0.1250)	0.238	0.226	0.066	0.058	0.015	5/64	0.078	0.044	0.145	0.135	0.50
6 (0.1380)	0.262	0.250	0.073	0.063	0.015	5/64	0.078	0.044	0.158	0.148	0.63
8 (0.1640)	0.312	0.298	0.087	0.077	0.015	3/32	0.094	0.052	0.194	0.184	0.75
10 (0.1900)	0.361	0.347	0.101	0.091	0.020	1/8	0.125	0.070	0.220	0.210	1.00
1/4 (0.2500)	0.437	0.419	0.132	0.122	0.031	5/32	0.156	0.087	0.290	0.280	1.00
5/16 (0.3125)	0.547	0.527	0.166	0.152	0.031	3/16	0.188	0.105	0.353	0.343	1.00
3/8 (0.3750)	0.656	0.636	0.199	0.185	0.031	7/32	0.219	0.122	0.415	0.405	1.25
7/16 (0.4375)	0.765	0.746	0.231	0.218	0.031	1/4	0.250	0.140	0.478	0.468	1.50
1/2 (0.5000)	0.875	0.851	0.265	0.245	0.046	5/16	0.312	0.175	0.560	0.540	2.00
5/8 (0.6250)	1.000	0.970	0.331	0.311	0.062	3/8	0.375	0.210	0.685	0.665	2.00
3/4 (0.7500)	1.125	1.105	0.375	0.355	0.062	7/16	0.437	0.245	0.740	0.720	2.50

**GENERAL NOTES:**

- (a) This product is designed and recommended for light fastening applications such as guards, hinges, etc. It is not suggested for use in critical high strength applications where socket head cap screws should normally be used.
- (b) For additional requirements, refer to Notes (6) through (14) and section 2, General Data, of this Standard.

**NOTES:**

- (1) *Length.* The length of the screw shall be measured, parallel to the axis of the screw, from the plane of the bearing surface under the head to the plane of the flat of the point. The portion of the screw contained within dimension, *L*, is commonly called the *shank*. The basic length dimension on the product shall be the nominal length expressed as a two-place decimal.
- (2) *Standard Lengths.* Standard length increments for socket button head cap screws shall be as tabulated below.

Nominal Screw Length	Standard Length Increment
0.13 through 0.25	0.06
0.25 through 1.00	0.13
1.00 through 2.00	0.25

**Table 11 Dimensions of Hexagon Socket Button Head Cap Screws (Cont'd)**

- (3) *Length Tolerances.* Allowable tolerance on length shall be as tabulated below.

Nominal Screw Length	Nominal Screw Size, Tolerances on Length	
	0 Through $\frac{3}{8}$ , Incl.	$\frac{1}{2}$ Through $\frac{5}{8}$ , Incl.
Up to 1.00, incl.	-0.03	-0.03
Over 1.00 to 2.00, incl.	-0.04	-0.06
Over 2.00	-0.04	-0.06

- (4) *Thread Length.* For screws of nominal lengths equal to or shorter than standard maximum lengths,  $L$ , listed in this Table, the complete (full-form) threads, measured with a thread ring gage having the thread chamfer and/or counterbore removed, shall extend to within two pitches (threads) of the bearing surface of the head. For longer screws, the length of the complete thread shall, at the option of the manufacturer, be between the minimum limit of twice the basic screw diameter plus 0.50 in. and the maximum limit within two pitches (threads) of the head. The unthreaded portion of the screw shall be at nominal diameter. The tolerance on the unthreaded portion (body diameter) of the screw shall be the same as Body Diameter,  $D$ , Table 1, Hexagon Socket Head Cap Screws.
- (5) *Screw Point Chamfer.* The point shall be flat or slightly concave and chamfered. The plane of the point shall be approximately normal to the axis of the screw. The chamfer shall extend slightly below the root of the thread, and the edge between flat and chamfer may be slightly rounded. The included angle of the point should be approximately 90 deg. Chamfering of screw sizes up to and including size 8 (0.164 in.) and lengths below  $0.75d$  shall be optional.
- (6) *Nominal Size.* Where specifying nominal size in decimals, zeros preceding decimal and in the fourth decimal place shall be omitted.
- (7) *Fillet.* The form of the fillet shall be optional, provided it flairs into the bearing surface between the minimum and maximum diameter,  $F$ . The fillet shall be a smooth and continuous curve having a bearing surface juncture radius not less than that tabulated below.

Nominal Screw Size	Minimum Juncture Radius	Nominal Screw Size	Minimum Juncture Radius
0	0.002	10	0.006
1	0.003	$\frac{1}{4}$	0.007
2	0.003	$\frac{5}{16}$	0.009
3	0.004	$\frac{3}{8}$	0.012
4	0.004	$\frac{7}{16}$	0.014
5	0.005	$\frac{1}{2}$	0.016
6	0.005	$\frac{5}{8}$	0.021
8	0.006	$\frac{3}{4}$	0.025

- (8) *Head Height.* Tabulated head heights represent metal-to-metal measurements; that is, the truncation of the rounded surface caused by the socket is not considered part of the head height.
- (9) See Table 18 for hexagon socket dimensions and Mandatory Appendix I for gaging of hexagon sockets.
- (10) *Bearing Surface.* The plane of the bearing surface shall be perpendicular to the axis of the shank within 2 deg obtained by holding the screw on the body or major thread diameter within 1 diameter of the bearing surface of the head, but beyond the maximum length of the fillet,  $F$ , rotating 360 deg, and inspecting on an optical comparator, or comparable inspection equipment.
- (11) *Runout*  
 (a) The runout of the head with the axis of the shank shall be within 3% of the maximum basic screw diameter dimension,  $D$ , or 0.008 in., whichever is greater.  
 Runout for (a) above is defined as the full indicator movement (FIM) obtained by holding the screw on the body or major thread diameter next to the head, but beyond the maximum length of the fillet,  $F$ , rotating the screw 360 deg, with the indicator riding on the outer surface of the head on the rounded portion, adjacent to, but not on the extreme periphery of, the head.  
 (b) The runout of the socket with the axis of the shank of the screw shall be within 3% of the maximum screw diameter,  $D$ , or 0.005 in., whichever is greater for nominal sizes through  $\frac{1}{2}$  in. diameter and 6% for nominal sizes above  $\frac{1}{2}$  in. diameter.  
 Runout for (b) above is defined as the full indicator movement (FIM) obtained by holding the screw on the body or major screw thread diameter within 1 diameter of the bearing surface of the head, but beyond the maximum length of the fillet,  $F$ , rotating 360 deg, indicating on each of the hexagon flats.
- (12) *Threads.* Threads shall be Unified external threads with radius root: Class 3A UNRC and UNRF Series.  
 Acceptability shall be based on System 22, ASME B1.3.  
 Class 3A does not provide a plating allowance.

**Table 11 Dimensions of Hexagon Socket Button Head Cap Screws (Cont'd)**

- (13) *Material*
- (a) *Steel, Alloy.* Button head cap screws shall be fabricated from an alloy steel and shall conform in all respects to ASTM F835.
- (b) *Steel, Corrosion-Resistant.* Button head cap screws shall be fabricated from austenitic corrosion-resistant steel and shall conform to ASTM F879.
- (14) *Designation.* To promote uniformity and understanding in communications relating to products conforming to this Standard, it is recommended that Hexagon Socket Button Head Cap Screws be designated in accordance with the following data, preferably in the sequence shown:
- (a) product name
- (b) designation of the standard
- (c) nominal size (number, fractional or decimal equivalent)
- (d) thread pitch
- (e) nominal length (fractional or decimal equivalent)
- (f) material
- (g) protective finish, if required
- EXAMPLES:
- Hexagon Socket Button Head Cap Screws, ASME B18.3, 10-32  $\times$   $\frac{3}{4}$ , Alloy Steel
- Hexagon Socket Button Head Cap Screws, ASME B18.3, 0.190-32  $\times$  0.750, Alloy Steel, Zinc Plated. (For plated products, see para. 1.7, Introductory Notes.)
- For the recommended B18 part identifying numbering (PIN) system, see ASME B18.24.

FINESZ 泛微

Table 12 Dimensions of Low Head Hexagon Socket Cap Screws

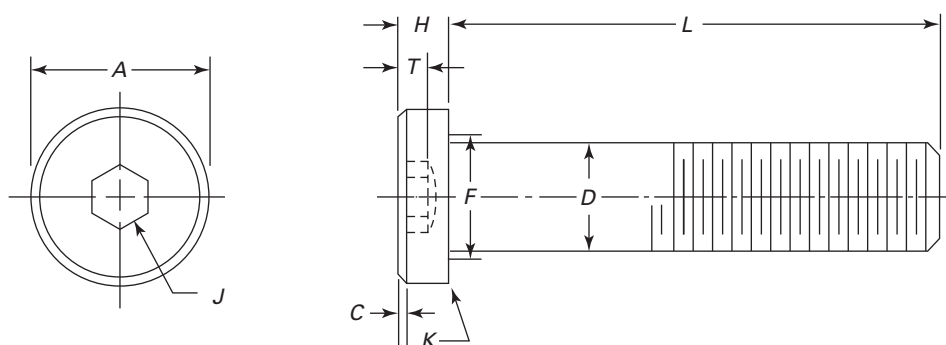

Nominal Size (Basic Screw Diameter) [Note (1)]	Body Diameter, <i>D</i> [Note (2)]		Head Diameter, <i>A</i> [Note (3)]		Head Height, <i>H</i>		Maximum Chamfer or Radius, <i>C</i> [Note (4)]	Nominal Hexagon Socket Size, <i>J</i>	Minimum Key Engagement, <i>T</i>	Maximum Chamfer or Radius, <i>K</i>	
	Max.	Min.	Max.	Min.	Max.	Min.					
4 (0.1120)	0.1120	0.1075	0.183	0.176	0.059	0.053	0.009	...	0.050	0.038	0.008
5 (0.1250)	0.1250	0.1202	0.205	0.198	0.065	0.059	0.012	$\frac{1}{16}$	0.062	0.044	0.008
6 (0.1380)	0.1380	0.1329	0.226	0.218	0.072	0.066	0.013	$\frac{1}{16}$	0.062	0.050	0.008
8 (0.1640)	0.1640	0.1585	0.270	0.262	0.085	0.079	0.014	$\frac{5}{64}$	0.078	0.060	0.008
10 (0.1900)	0.1900	0.1840	0.312	0.303	0.098	0.092	0.018	$\frac{3}{32}$	0.094	0.072	0.008
$\frac{1}{4}$ (0.2500)	0.2500	0.2435	0.375	0.365	0.127	0.121	0.025	$\frac{1}{8}$	0.125	0.094	0.010
$\frac{5}{16}$ (0.3125)	0.3125	0.3053	0.437	0.431	0.158	0.152	0.033	$\frac{5}{32}$	0.156	0.110	0.010
$\frac{3}{8}$ (0.3750)	0.3750	0.3678	0.562	0.550	0.192	0.182	0.040	$\frac{3}{16}$	0.188	0.115	0.010
$\frac{7}{16}$ (0.4375)	0.4375	0.4294	0.625	0.618	0.223	0.213	0.047	$\frac{7}{32}$	0.219	0.135	0.015
$\frac{1}{2}$ (0.5000)	0.5000	0.4919	0.750	0.743	0.254	0.244	0.055	$\frac{1}{4}$	0.250	0.151	0.015
$\frac{5}{8}$ (0.6250)	0.6250	0.6163	0.875	0.867	0.316	0.306	0.070	$\frac{5}{16}$	0.312	0.250	0.015

## GENERAL NOTES:

- (a) This product, although a high-strength precision fastener, is recommended for lighter fastening applications. It is not suggested for use in critical high-strength applications where socket head cap screws should normally be used. They are designed to be used in applications where head height clearance is a problem. Because of their reduced head height and smaller socket size, they normally cannot be properly preloaded as a standard socket cap screw and should not be subjected to high dynamic loads.
- (b) For additional requirements, refer to Notes (5) through (12), and also section 2, General Data, of this Standard.

## NOTES:

- (1) *Nominal Size.* Where specifying nominal size in decimals, zeros preceding decimal and in the fourth decimal place shall be omitted.
- (2) *Body.* The term *body* refers to the unthreaded cylindrical portion of the shank for those screws not threaded to the head.
- (3) *Head Diameter.* Heads shall be plain, not knurled.
- (4) *Head Chamfer.* The top of the head shall be flat. The intersection of the top of the head and side of the head may be chamfered or radiused within the limits of *C*, at the manufacturer's option.
- (5) *Bearing Surface.* The plane of the bearing surface shall be perpendicular to the axis of the shank, with a maximum deviation of 1 deg, obtained by holding the screw on the body or major thread diameter within 1 diameter of the bearing surface of the head, but beyond the maximum length of the fillet,  $F_L$ , and inspecting on an optical comparator, or comparable inspection equipment, rotating the shank 360 deg.
- (6) *Edge of Head.* The edge between the bearing surface and the side of the head may be broken (rounded or chamfered), but the radius or chamfer measured along the bearing surface shall not exceed the values listed for *K*.

**Table 12 Dimensions of Low Head Hexagon Socket Cap Screws (Cont'd)**

## NOTES:

- (7) *Runout*
- (a) The runout of the head with the axis of the shank shall be within 2% of the maximum basic screw diameter dimension,  $D$ , or 0.006 in., whichever is greater.
- Runout for (a) above is defined as the full indicator movement (FIM) obtained by holding the screw on the body or major screw thread diameter within 1 diameter of the bearing surface of the head, but beyond the maximum length of the fillet,  $F_L$ , rotating 360 deg and indicating on the outside diameter of the head.
- (b) The runout of the socket with the axis of the shank of the screw shall be within 3% of the maximum screw diameter,  $D$ , or 0.005 in., whichever is greater for sizes through  $\frac{1}{2}$  in. diameter and 6% for sizes above  $\frac{1}{2}$  in. diameter.
- Runout for (b) above is defined as the full indicator movement (FIM) obtained by holding the screw on the body or major screw thread diameter within 1 diameter of the bearing surface of the head, but beyond the maximum length of the fillet,  $F_L$ , rotating 360 deg, indicating on each of the six hexagon flats.
- (c) The conformance of screws to shank straightness or camber limitations set forth as  $D_e$  in Table 6 shall be checked by the use of the procedures and typical gage illustrated in ASME B18.2.9.
- (8) *Fillet*. For all lengths of screws, the form of the underhead fillet shall be optional, as depicted in the illustration above Tables 2 and 3, provided it is a smooth and continuous concave curve fairing into the bearing surface of the head, and the screw shank is within the envelope established by the limits for fillet extension, length, and juncture radius specified in Tables 2 and 3.
- (9) *Length*. The length of the screw shall be measured parallel to the axis of the screw from the plane of the bearing surface under the head to the plane of the flat of the point. The portion of the screw contained within dimension  $L$  is commonly called the *shank*. The basic length dimension on the product shall be the nominal length expressed as a two-placed decimal.
- (10) All other characteristics are the same as Notes (3) through (6), (8), (13), (14), and (18) through (21) of Table 1 for socket head cap screws.
- [EXCEPTIONS: Since these are not full-size socket screw products, the mechanical requirements of ASTM A574 will not apply.]
- (11) The minimum tensile requirements for Alloy Steel Low Head Socket Cap Screws are the same as for Alloy Steel Socket Button Cap Screws, for the same length and diameter, as per ASTM F835.
- (12) *Designation*. To promote uniformity and understanding in communications relating to products conforming to this Standard, it is recommended that Hexagon Low Head Socket Cap Screws be designated in accordance with the following data, preferably in the sequence shown:
- (a) product name  
 (b) designation of the standard  
 (c) nominal size (number, fractional or decimal equivalent)  
 (d) thread pitch  
 (e) nominal length (fractional or decimal equivalent)  
 (f) material  
 (g) protective finish, if required
- EXAMPLES:  
 Hexagon Low Head Socket Cap Screws, ASME 818.3, 8-32  $\times$   $\frac{3}{4}$ , Alloy Steel  
 Hexagon Low Head Socket Cap Screws, ASME B18.3, 0.164-32  $\times$  0.750, Alloy Steel, Zinc Plated. (For plated products, see para. 1.7, Introductory Notes.)

For the recommended B18 part identifying numbering system (PIN), see ASME B18.24.

**Table 13 Dimensions of Hexagon Socket Head Shoulder Screws**

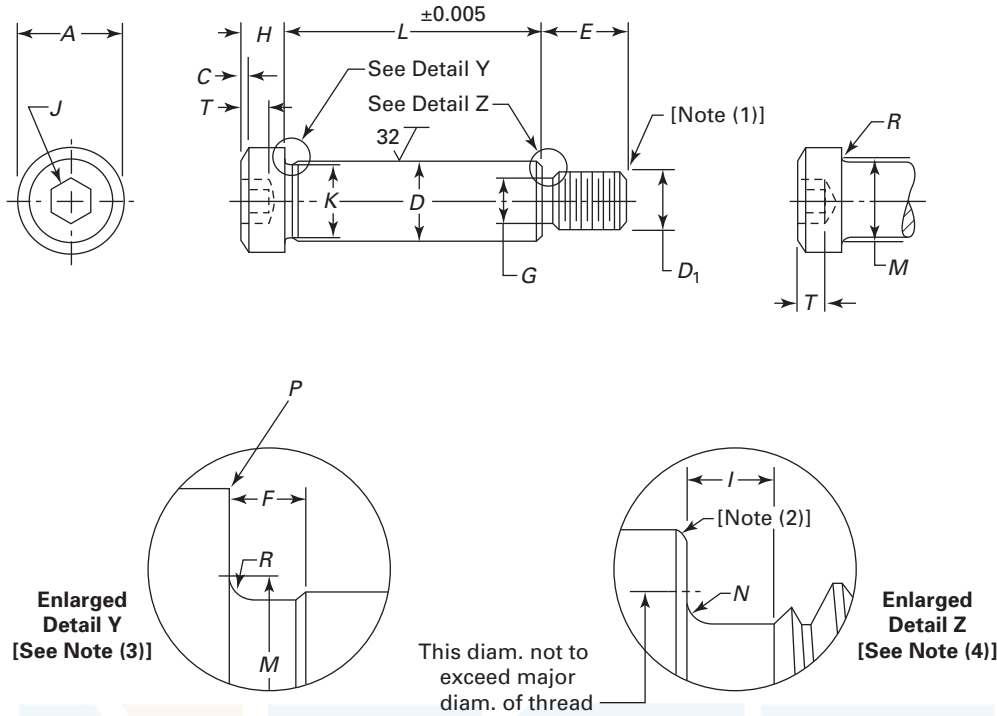

Nominal Size (Basic Shoulder Diameter)	Shoulder Diameter, <i>D</i>		Head Diameter, <i>A</i>		Head Height, <i>H</i>		Max. Chamfer or Radius, <i>C</i>	Nominal Hexagon Socket Size, <i>J</i>	Min. Key Engagement, <i>T</i>	Max. Fillet Transition Diameter, <i>M</i>	Min. Head Fillet Radius, <i>R</i>
	Max.	Min.	Max.	Min.	Max.	Min.					
$\frac{1}{8}$ (0.1250)	0.1230	0.1210	0.250	0.235	0.125	0.115	0.008	$\frac{5}{64}$ 0.078	0.067	0.138	0.006
$\frac{5}{32}$ (0.1560)	0.1540	0.1520	0.281	0.266	0.125	0.115	0.008	$\frac{3}{32}$ 0.094	0.067	0.172	0.007
$\frac{3}{16}$ (0.1875)	0.1850	0.1830	0.312	0.296	0.156	0.146	0.012	$\frac{3}{32}$ 0.094	0.079	0.207	0.008
$\frac{1}{4}$ (0.2500)	0.2480	0.2460	0.375	0.357	0.188	0.177	0.020	$\frac{1}{8}$ 0.125	0.094	0.276	0.009
$\frac{5}{16}$ (0.3125)	0.3105	0.3085	0.438	0.419	0.219	0.209	0.026	$\frac{5}{32}$ 0.156	0.117	0.345	0.012
$\frac{3}{8}$ (0.3750)	0.3730	0.3710	0.562	0.543	0.250	0.240	0.031	$\frac{3}{16}$ 0.188	0.141	0.413	0.015
$\frac{1}{2}$ (0.5000)	0.4980	0.4960	0.750	0.729	0.312	0.302	0.040	$\frac{1}{4}$ 0.250	0.188	0.550	0.020
$\frac{5}{8}$ (0.6250)	0.6230	0.6210	0.875	0.853	0.375	0.365	0.050	$\frac{5}{16}$ 0.312	0.234	0.687	0.024
$\frac{3}{4}$ (0.7500)	0.7480	0.7460	1.000	0.977	0.500	0.490	0.069	$\frac{3}{8}$ 0.375	0.281	0.826	0.030
1 (1.0000)	0.9980	0.9960	1.312	1.287	0.625	0.610	0.083	$\frac{1}{2}$ 0.500	0.375	1.098	0.040
$1\frac{1}{4}$ (1.2500)	1.2480	1.2460	1.750	1.723	0.750	0.735	0.102	$\frac{5}{8}$ 0.625	0.469	1.368	0.050
$1\frac{1}{2}$ (1.5000)	1.4980	1.4960	2.125	2.095	1.000	0.980	0.138	$\frac{7}{8}$ 0.875	0.656	1.638	0.060
$1\frac{3}{4}$ (1.7500)	1.7480	1.7460	2.375	2.345	1.125	1.105	0.157	1 1.000	0.750	1.908	0.070
2 (2.0000)	1.9980	1.9960	2.750	2.720	1.250	1.230	0.176	$1\frac{1}{4}$ 1.250	0.937	2.178	0.080

**Table 13 Dimensions of Hexagon Socket Head Shoulder Screws (Cont'd)**

Nominal Size (Basic Shoulder Diameter)	Min. Shoulder Neck Diameter, <i>K</i>	Max. Shoulder Neck Width, <i>F</i>	Nominal Thread Diameter, <i>D</i> <sub>1</sub>		Threads, in.	Thread Neck Diameter, <i>G</i>		Max. Thread Neck Width, <i>I</i>	Thread Neck Fillet, <i>N</i>		Basic Thread Length, <i>E</i>	Max. Chamfer or Radius, <i>P</i>
						Max.	Min.		Max.	Min.		
1/8 (0.1250)	0.108	0.040	4	0.1120	40	0.076	0.069	0.078	0.016	0.010	0.157	0.008
5/32 (0.1560)	0.140	0.040	6	0.1380	32	0.100	0.093	0.063	0.018	0.012	0.187	0.008
3/16 (0.1875)	0.154	0.040	8	0.1640	32	0.120	0.112	0.069	0.018	0.012	0.189	0.008
1/4 (0.2500)	0.227	0.093	10	0.1900	24	0.142	0.133	0.083	0.023	0.017	0.375	0.010
5/16 (0.3125)	0.289	0.093	1/4	0.2500	20	0.193	0.182	0.100	0.028	0.022	0.438	0.010
3/8 (0.3750)	0.352	0.093	5/16	0.3125	18	0.249	0.237	0.111	0.031	0.025	0.500	0.010
1/2 (0.5000)	0.477	0.093	3/8	0.3750	16	0.304	0.291	0.125	0.035	0.029	0.625	0.010
5/8 (0.6250)	0.602	0.093	1/2	0.5000	13	0.414	0.397	0.154	0.042	0.036	0.750	0.015
3/4 (0.7500)	0.727	0.093	5/8	0.6250	11	0.521	0.502	0.182	0.051	0.045	0.875	0.015
1 (1.0000)	0.977	0.125	3/4	0.7500	10	0.638	0.616	0.200	0.055	0.049	1.000	0.020
1 1/4 (1.2500)	1.227	0.125	7/8	0.8750	9	0.750	0.726	0.222	0.062	0.056	1.125	0.020
1 1/2 (1.5000)	1.478	0.125	1 1/8	1.1250	7	0.964	0.934	0.286	0.072	0.066	1.500	0.020
1 3/4 (1.7500)	1.728	0.125	1 1/4	1.2500	7	1.089	1.059	0.286	0.072	0.066	1.750	0.020
2 (2.0000)	1.978	0.125	1 1/2	1.5000	6	1.307	1.277	0.333	0.102	0.096	2.000	0.020

GENERAL NOTE: For additional requirements, refer to Notes (5) through (16) and section 2, General Data, of this Standard.

NOTES:

- (1) *Screw Point Chamfer.* The point shall be flat or slightly concave, and chamfered. The plane of the point shall be approximately normal to the axis of the screw. The chamfer shall extend slightly below the root of the thread, and the edge between flat and chamfer may be slightly rounded. The included angle of the point should be approximately 90 deg.
- (2) *Edge of Shoulder.* The edge of the shoulder may be broken. The radius or chamfer shall not exceed 0.005 in. for shoulders to 0.373 in. diameter and 0.008 in. for larger diameters. (See Detail Z.)
- (3) *Head Diameter.* The head may be plain or knurled at the option of the manufacturer.
- (4) *Neck Under Shoulder.* The neck under the shoulder shall allow the shoulder to seat against the face of a standard basic GO thread ring gage.
- (5) *Shoulder.* Shoulder refers to the enlarged unthreaded portion of the screw, the diameter of which serves as the basis for derivation of the nominal size.
- (6) *Length.* The length of the shoulder screw shall be measured, parallel to the axis of the screw, from the plane of the bearing surface under the head to the plane of the shoulder at the threaded end. The basic length dimension on the product shall be the nominal length expressed as a three-placed decimal.
- (7) *Standard Lengths.* The difference between consecutive lengths of standard shoulder screws shall be as designated in the following tabulation.

Nominal Screw Length	Standard Length Increment
0.25 through 0.75	0.13
0.75 through 5.00	0.25
Over 5.00	0.50

- (8) *Neck and Fillet Under Head.* Screws may be necked under the head at the option of the manufacturer. The fillet extension above *D*, at the intersection of the head bearing surface and neck or shoulder, shall be controlled by maximum dimension, *M*, and minimum radius of curvature, *R*. (See Detail Y.)
- (9) See Table 18 for hexagon socket dimensions and Mandatory Appendix I for gaging of hexagon sockets.
- (10) *Threads.* Threads shall be Unified external thread: Class 3A, UNC Series. Acceptability is to be based on System 22, ASME B1.3. Class 3A does not provide a plating allowance. When plated products are required, it is recommended that they be procured from the manufacturer (see para. 1.10).
- (11) *Head Chamfer.* The top of the head shall be flat. The intersection of the top of the head and the side of the head may be chamfered or radiused within the limits of *C*, at the manufacturer's option.
- (12) *Thread Length Tolerance.* Tolerance on thread length *E* shall be -0.020 in. for screw thread sizes up to 3/8 in., inclusive, and -0.030 in. for screw thread sizes larger than 3/8 in.
- (13) *Bearing Surface.* The plane of the bearing surface shall be perpendicular to the axis of the shank, within 2 deg obtained by holding the shoulder screw on the shoulder or major thread diameter within 1 diameter of the bearing surface of the head, rotating 360 deg, and inspecting on an optical comparator, or comparable inspection equipment.

**Table 13 Dimensions of Hexagon Socket Head Shoulder Screws (Cont'd)****(14) Runout**

(a) The runout of the head with the axis of the shoulder shall be within 2% of the nominal size, or 0.006 in., whichever is greater. Runout for (a) above is defined as the full indicator movement (FIM) obtained by holding the shoulder screw on the shoulder within 1 diameter of the bearing surface of the head, but beyond the maximum length of  $F$ , rotating the shoulder screw 360 deg and indicating on the outside diameter of the head.

(b) The runout of the socket with the axis of the shank of the shoulder screw shall be within 3% of the maximum shoulder diameter,  $D$ , or 0.005 in., whichever is greater for nominal sizes through  $\frac{1}{2}$ -in. diameter and 6% for nominal sizes above  $\frac{1}{2}$  diameter.

Runout for (b) above is defined as the full indicator movement (FIM) obtained by holding the shoulder screw on the shoulder or major screw thread diameter within 1 diameter of the bearing surface of the head, but beyond the maximum length of  $F$ , rotating 360 deg and indicating on each of the six hexagon flats.

Runout between the screw thread and shoulder shall be checked by firmly seating the screw thread in a threaded bushing. The thread of the bushing must be basic size and the bushing O.D. must be concentric with its axis, and the ends must be square with its axis.

The runout between the screw thread and shoulder shall be a maximum of 0.004 in. full indicator movement (FIM) when checked on the shoulder diameter at a distance of 0.188 in. from the shoulder at the threaded end, and at within 0.005 in. full indicator movement (FIM) per inch of shoulder length, with a maximum of 0.025 in., when checked on the shoulder a distance of  $2F$  from the underside of the head. The bushing is to be rotated, in a V block or equivalent, 360 deg, with the indicator riding on the major diameter of the shoulder in the appropriate locations.

The squareness of the shoulder shall be perpendicular to the axis of the shoulder screw, within 2 deg obtained by holding the shoulder screw on the shoulder diameter within 1 diameter of the thread end of the shoulder, rotating 360 deg, and inspecting on an optical comparator or comparable inspection equipment.

**(15) Material.** Shoulder screws shall be fabricated from an alloy steel having one or more of the following alloying elements: chromium, nickel, molybdenum, or vanadium, in sufficient quantity to ensure that the specified hardness range of 32 HRC to 43 HRC at the surface is met when hardened by quenching from the austenitizing temperature and tempered at not lower than 343°C (650°F). Decarburization and carburization limits shall be the same as those specified for socket head cap screws in ASTM A574.

Shoulder screws shall meet the following mechanical property requirements: the hardness shall be 32 HRC to 43 HRC anywhere in the section.

There are no other specific mechanical tests called out, but for design considerations, these shoulder screws should develop the following:

- (a) 140,000 psi minimum tensile strength based on the minimum thread neck area
- (b) 84,000 psi minimum shear strength in the thread neck area, based on the minimum thread neck area
- (c) 84,000 psi minimum shear strength in the shoulder, based on the minimum shoulder area

**(16) Designation.** To promote uniformity and understanding in communications relating to products conforming to this Standard, it is recommended that Hexagon Socket Head Shoulder Screws be designated in accordance with the following data, preferably in the sequence shown:

- (a) product name
- (b) designation of the standard
- (c) nominal size (number, fractional or decimal equivalent)
- (d) nominal length (fractional or decimal equivalent)
- (e) material.
- (f) protective finish, if required (for plated products, see para. 1.7)

**EXAMPLES:**

Hexagon Socket Head Shoulder Screws, ASME B18.3,  $\frac{1}{4} \times 1\frac{1}{4}$ , Alloy Steel

Hexagon Socket Head Shoulder Screws, ASME B18.3, 0.250  $\times$  1.250, Alloy Steel, Phosphate Coated

For the recommended B18 part identifying numbering system (PIN), see ASME B18.24.



Table 14 Dimensions of Hexagon Socket Set Screws

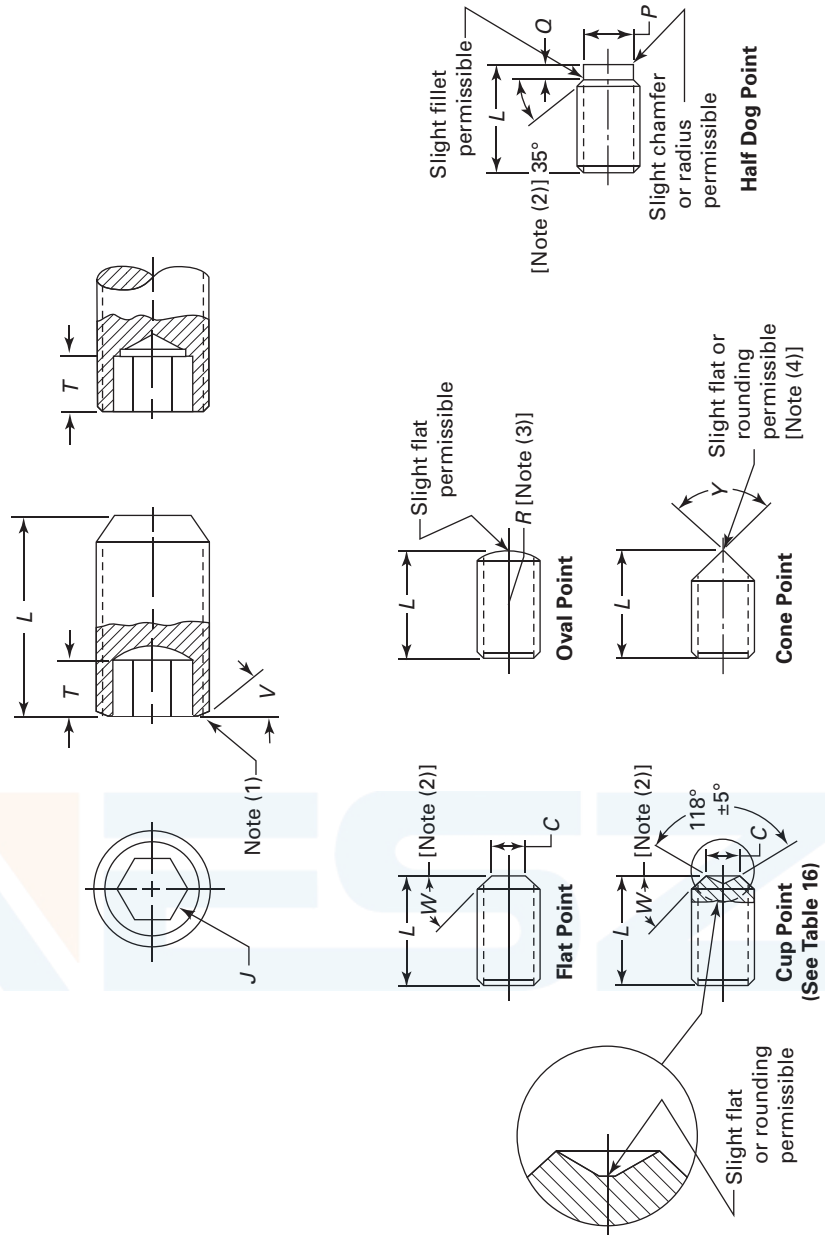

Table 14 Dimensions of Hexagon Socket Set Screws (Cont'd)

Nominal Size (Basic Screw Diameter)	Nominal Hexagon Socket Size, J	Minimum Key Engagement to Develop Functional Capability of Key, T	Hex Socket, T <sub>H</sub>	Cup and Flat Point				Half Dog Point				Shortest Optimum Nominal Length to Which T <sub>H</sub> Applies, B				Shortest Optimum Nominal Length to Which T <sub>S</sub> Applies, B <sub>1</sub>			
				Diameters, C		Oval Point Radius, R		Diameter, P		Length, Q		Cup and Flat Points		90 deg Cone and Dog Point		Cup and Flat Points		90 deg Cone and Dog Point	
				Max.	Min.	Max.	Min.	Max.	Min.	Max.	Min.	Cup and Flat Points	90 deg Cone and Dog Point	Cup and Flat Points	90 deg Cone and Dog Point	Cup and Flat Points	90 deg Cone and Dog Point		
0	(0.0600)	...	0.050	0.027	0.045	0.09	0.037	0.017	0.013	0.040	0.037	0.017	0.013	0.06	0.13	0.13	0.13		
1	(0.0730)	...	0.060	0.033	0.055	0.09	0.045	0.021	0.017	0.049	0.045	0.021	0.017	0.13	0.13	0.13	0.13		
2	(0.0860)	...	0.060	0.039	0.064	0.13	0.057	0.024	0.020	0.057	0.053	0.024	0.020	0.13	0.13	0.13	0.13		
3	(0.0990)	...	0.070	0.045	0.074	0.13	0.066	0.027	0.023	0.066	0.062	0.027	0.023	0.13	0.13	0.13	0.13		
4	(0.1120)	...	0.070	0.051	0.084	0.19	0.075	0.030	0.026	0.075	0.070	0.030	0.026	0.13	0.13	0.13	0.13		
5	(0.1250)	1/16	0.080	0.057	0.094	0.19	0.083	0.033	0.027	0.083	0.078	0.033	0.027	0.13	0.13	0.13	0.13		
5	(0.1250)	1/16	0.080	0.057	0.094	0.19	0.083	0.033	0.027	0.083	0.078	0.033	0.027	0.13	0.13	0.13	0.13		
6	(0.1380)	1/16	0.080	0.064	0.104	0.19	0.092	0.038	0.032	0.092	0.087	0.038	0.032	0.13	0.13	0.13	0.13		
6	(0.1380)	1/16	0.080	0.064	0.104	0.19	0.092	0.038	0.032	0.092	0.087	0.038	0.032	0.13	0.13	0.13	0.13		
8	(0.1640)	3/64	0.090	0.076	0.123	0.25	0.109	0.043	0.037	0.109	0.103	0.043	0.037	0.19	0.19	0.19	0.19		
10	(0.1900)	3/32	0.100	0.088	0.142	0.25	0.127	0.049	0.041	0.127	0.120	0.049	0.041	0.19	0.19	0.19	0.19		
1/4	(0.2500)	1/8	0.125	0.118	0.188	0.31	0.156	0.067	0.059	0.156	0.149	0.067	0.059	0.25	0.25	0.25	0.25		
5/16	(0.3125)	5/32	0.156	0.156	0.234	0.38	0.203	0.082	0.074	0.203	0.195	0.082	0.074	0.31	0.31	0.31	0.31		
3/8	(0.3750)	3/16	0.188	0.194	0.281	0.44	0.250	0.099	0.089	0.250	0.241	0.099	0.089	0.38	0.38	0.38	0.38		
7/16	(0.4375)	7/32	0.219	0.232	0.328	0.50	0.297	0.114	0.104	0.297	0.287	0.114	0.104	0.44	0.44	0.44	0.44		
1/2	(0.5000)	1/4	0.250	0.270	0.375	0.57	0.344	0.130	0.120	0.344	0.334	0.130	0.120	0.50	0.50	0.50	0.50		
5/8	(0.6250)	5/16	0.312	0.347	0.469	0.75	0.469	0.164	0.148	0.469	0.456	0.164	0.148	0.63	0.63	0.63	0.63		
3/4	(0.7500)	3/8	0.375	0.425	0.562	0.88	0.562	0.196	0.180	0.562	0.549	0.196	0.180	0.75	0.75	0.75	0.75		
7/8	(0.8750)	1/2	0.500	0.502	0.656	1.00	0.656	0.227	0.211	0.656	0.642	0.227	0.211	0.88	0.88	0.88	0.88		
1	(1.0000)	9/16	0.562	0.579	0.750	1.13	0.750	0.260	0.240	0.750	0.734	0.260	0.240	1.00	1.00	1.00	1.00		
1 1/8	(1.1250)	5/8	0.562	0.655	0.844	1.25	0.844	0.291	0.271	0.844	0.826	0.291	0.271	1.25	1.25	1.25	1.25		
1 1/4	(1.2500)	3/4	0.625	0.733	0.938	1.50	0.938	0.323	0.303	0.938	0.920	0.323	0.303	1.25	1.25	1.25	1.25		
1 3/8	(1.3750)	7/8	0.625	0.848	1.031	1.63	1.031	0.354	0.334	1.031	1.011	0.354	0.334	1.50	1.50	1.50	1.50		
1 1/2	(1.5000)	3/4	0.750	0.886	1.125	1.75	1.125	0.385	0.365	1.125	1.105	0.385	0.365	1.50	1.50	1.50	1.50		
1 3/4	(1.7500)	1	1.000	1.086	1.312	2.00	1.312	0.448	0.428	1.312	1.289	0.448	0.428	1.75	1.75	1.75	1.75		
2	(2.0000)	1	1.000	1.244	1.500	2.25	1.500	0.510	0.490	1.500	1.474	0.510	0.490	2.00	2.00	2.00	2.00		

**Table 14 Dimensions of Hexagon Socket Set Screws (Cont'd)**

GENERAL NOTE: For additional requirements, refer to Notes (5) through (15) and section 2, General Data, of this Standard.

NOTES:

- (1) *Face.* The plane of the face on the socket end of the screw shall be approximately normal to the axis of the screw, and shall be chamfered on screws longer than lengths listed in this Table, columns *B* and *B<sub>1</sub>*. The chamfer angle, *V*, shall be between 30 deg and 45 deg. The chamfer shall extend slightly below the root diameter of the thread and the edge between flat and chamfer may be slightly rounded. For screws equal to or shorter than the lengths listed in this Table, columns *B* and *B<sub>1</sub>*, or screws 0.250 in. diameter or greater, with a national coarse thread, including lengths longer than listed in this Table, columns *B* and *B<sub>1</sub>*, chamfering shall be at the option of the manufacturer. If chamfered, the chamfer angle, *V*, shall not exceed 45 deg.
- (2) *Point Angles.* Point angles specified shall apply only to those portions of the angles that lie below the root diameter of the thread. The angles may vary in the threaded portions due to manufacturing processes.
- (3) *W* shall be 45 deg, +5 deg –0 deg, for screws of lengths equal to or longer than the lengths listed in this Table, columns *B* and *B<sub>1</sub>*, and 30 deg minimum for shorter screws.
- (4) *Oval Point Radius Tolerance.* The tolerance shall be +0.015 in. for screw nominal sizes through 5 (0.125 in.) and +0.031 in. for screw nominal sizes 6 (0.138 in.) and larger.
- (5) *Cone Point Configuration.* The apex of the cone may be flattened or rounded to the extent of 10% of the basic diameter of the screw.
- (6) *Nominal Size.* Where specifying nominal size in decimals, zeros preceding decimal and in the fourth decimal place shall be omitted.
- (7) *Length.* The length of the screw shall be measured overall, parallel to the axis of the screw. The basic length dimension on the product shall be the nominal length expressed as a two-place decimal.
- (8) *Standard Lengths.* Standard length increments for set screws shall be as tabulated below.

Nominal Screw Length	Standard Length Increment
0.13 through 0.19*	0.03
0.19 through 0.50	0.06
0.50 through 1.00	0.13
1.00 through 2.00	0.25
2.00 through 6.00	0.50
Over 6.00	1.00

\*A nominal screw length of 0.13 through 0.19 is applicable only to nominal sizes 0 (0.060 in.) through 3 (0.099 in.), inclusive.

(8) *Hexagon Sockets.* See Table 6 for hexagon socket dimensions and Mandatory Appendix I for gaging of hexagon sockets.

(9) *Socket Depths.* The key engagement dimensions shall apply only to nominal screw lengths equal to or longer than the lengths listed in this Table, columns *B* and *B<sub>1</sub>*, respectively. For hexagon socket key engagement dimensions in screws of shorter nominal lengths than those listed in column *B* of this Table, see Table 15.

(10) *Half Dog Point Runout.* The runout of the half dog point shall not exceed 3% of the nominal size and shall not exceed 0.010 FIM for nominal sizes up to and including 3/4 in. diameter and 0.020 FIM for nominal sizes over 3/4 in. diameter.

Runout is defined as the full indicator movement (FIM) obtained by holding on the thread major diameter near the half dog point, and rotating the screw 360 deg and indicating on the half dog point diameter.

**Table 14 Dimensions of Hexagon Socket Set Screws (Cont'd)**

(11) *Tolerance on Length.* Tolerance on length of set screws shall be as tabulated below.

Nominal Screw Length	Tolerance on Length
Up to 0.63, incl.	±0.01
Over 0.63 to 2.00, incl.	±0.02
Over 2.00 to 6.00, incl.	±0.03
Over 6.00	±0.06

(12) *Threads.* Threads shall be Unified external thread: Class 3A, UNC and UNF Series.

Thread lead deviation is controlled by standard thread gages within a thread length equal to 1.5 basic thread diameters. When using set screws longer than 1.5 basic diameters in length, the pitch diameter of the set screw may need to be reduced, or the tapped hole's pitch diameter may need to be increased to avoid interference during assembly.

Thread acceptability shall be based on System 22, ASME B1.3. NOT GO gaging shall not be required for set screws equal to or shorter than 7-pitch lengths.

Class 3A threads do not provide a plating allowance. When set screws must be plated, they should be manufactured with an undersized pitch diameter to accommodate the plating.

(13) *Material*

(a) *Steel, Alloy.* Socket set screws shall be fabricated from alloy steel and shall conform in all respects to ASTM F912.

(b) *Steel, Corrosion-Resistant.* Socket set screws shall be fabricated from austenitic corrosion-resistant steel and shall conform in all respects to ASTM F880.

(14) *Flat Point.* The plane of the end on the flat point shall be perpendicular to the axis of the thread within 2 deg obtained by holding the screw on the major thread diameter near the flat point, and inspecting on an optical comparator or comparable inspection equipment.

(15) *Designation.* To promote uniformity and understanding in communications relating to products conforming to this Standard, it is recommended that Hexagon Socket Set Screws be designated in accordance with the following data, preferably in the sequence shown:

- (a) product name and point style
- (b) designation of the standard
- (c) nominal size (number, fractional or decimal equivalent)
- (d) thread pitch
- (e) nominal length (fractional or decimal equivalent)
- (f) material
- (g) protective finish, if required

EXAMPLES:

Hexagon Socket Set Screw, Cup Point, ASME B18.3,  $\frac{1}{4}$ -20 x  $\frac{1}{4}$ , Alloy Steel

Hexagon Socket Set Screw, Cup Point, ASME B18.3, 6-32 x 0.250, Corrosion-Resistant Steel

For the recommended B18 part identifying numbering system (PIN), see ASME B18.24.

**Table 15 Hexagon Key Engagements for Short Length Set Screws**

Nominal Size (Basic Screw Diameter)	Nominal Hexagon Socket Size, <i>J</i>		Nominal Screw Length, <i>L</i>	Minimum Key Engagement		
				Cup [Note (1)] and Flat Point	118 deg Cone and Oval Point	Half Dog Point
0 (0.0600)	...	0.028	0.06	0.030	0.028	Note (2)
			0.09	0.040	0.040 [Note (3)]	0.028
1 (0.0730)	...	0.035	0.06	0.030	0.029	Note (2)
			0.09	0.040	0.040 [Note (3)]	0.040
2 (0.0860)	...	0.035	0.06	0.030	0.029	Note (2)
			0.09	0.040	0.040	0.035
3 (0.0990)	...	0.050	0.09	0.040	0.039	Note (2)
			0.13	0.055	0.040 [Note (3)]	0.045
4 (0.1120)	...	0.050	0.09	0.045	0.039	Note (2)
			0.13	0.060	0.045	0.045
5 (0.1250)	1/16	0.062	0.09	0.040	0.039	Note (2)
			0.13	0.060	0.045	0.045
6 (0.1380)	1/16	0.062	0.09	0.040	0.039	Note (2)
			0.13	0.060	0.045	0.045
			0.16	0.070	0.065	0.065
8 (0.1640)	5/64	0.078	0.13	0.060	0.050	0.045
			0.16	0.070	0.060	0.060
			0.19	Note (4)	0.065	0.065
10 (0.1900)	3/32	0.094	0.13	0.060	0.042	0.042
			0.19	Note (4)	0.060	0.060
1/4 (0.2500)	1/8	0.125	0.19	0.090	0.065	0.055
			0.25	Note (4)	0.110	0.090
5/16 (0.3125)	5/32	0.156	0.25	0.125	0.099	0.090
			0.31	Note (4)	0.140	0.105
3/8 (0.3750)	3/16	0.188	0.25	0.110	0.090	0.075
			0.31	0.140	0.115	0.105
			0.38	Note (4)	0.165	0.155
7/16 (0.4375)	7/32	0.219	0.38	0.160	0.125	0.125
			0.44	Note (4)	0.160	0.160
1/2 (0.5000)	1/4	0.250	0.38	0.175	0.130	0.130
			0.44	0.215	0.155	0.155
			0.50	Note (4)	0.195	0.195
5/8 (0.6250)	5/16	0.312	0.50	0.205	0.145	0.145
3/4 (0.7500)	3/8	0.375	0.63	0.255	0.190	0.190
			0.75	Note (4)	0.325	0.295
7/8 (0.8750)	1/2	0.500	0.75	0.330	0.255	0.255
			0.87	Note (4)	0.419	0.330
1 (1.0000)	9/16	0.562	0.75	0.280	0.175	0.175
			0.87	0.380	0.280	0.280
			1.00	Note (4)	0.380	0.380

**Table 15 Hexagon Key Engagements for Short Length Set Screws (Cont'd)**

## GENERAL NOTES:

- (a) CAUTION: The use of short-length set screws listed in this Table can result in failure of the socket, key, or mating threads during tightening because key engagement and thread length are less than optimum. Therefore, it is strongly recommended that screws of lengths equal to or greater than the lengths specified in columns  $B$  and  $B_1$  of Table 14 be used wherever possible.
- (b) See Table 14, and the illustrations and notes thereto, for additional dimensions and specifications.

## NOTES:

- (1) Cup angle may be 118 deg or 130 deg, +5 deg, depending upon screw length and manufacturing process.
- (2) These sizes are impractical to manufacture because of point configuration and short length.
- (3) Cone point angle for these lengths shall be 90 deg; see column  $Y$  of Table 14.
- (4) These screws are covered in Table 14.

**Table 16 Dimensions of Optional Cup Points**

Nominal Size (Basic Screw Diameter)	Point Diameter, $C_1$		Point Diameter, $C_2$		Point Length, $S$	
	Max.	Min.	Max.	Min.	Max.	Min.
0 (0.0600)	0.032	0.027	0.027	0.022	0.007	0.004
1 (0.0730)	0.038	0.033	0.035	0.030	0.008	0.005
2 (0.0860)	0.043	0.038	0.043	0.038	0.010	0.007
3 (0.0990)	0.050	0.045	0.051	0.046	0.011	0.007
4 (0.1120)	0.056	0.051	0.059	0.054	0.013	0.008
5 (0.1250)	0.062	0.056	0.068	0.063	0.014	0.009
6 (0.1380)	0.069	0.062	0.074	0.068	0.017	0.012
8 (0.1640)	0.082	0.074	0.090	0.084	0.021	0.016
10 (0.1900)	0.095	0.086	0.101	0.095	0.024	0.019
$\frac{1}{4}$ (0.2500)	0.125	0.114	0.156	0.150	0.027	0.022
$\frac{5}{16}$ (0.3125)	0.156	0.144	0.190	0.185	0.038	0.033
$\frac{3}{8}$ (0.3750)	0.187	0.174	0.241	0.236	0.041	0.036
$\frac{7}{16}$ (0.4375)	0.218	0.204	0.286	0.281	0.047	0.042
$\frac{1}{2}$ (0.5000)	0.250	0.235	0.333	0.328	0.054	0.049
$\frac{5}{8}$ (0.6250)	0.312	0.295	0.425	0.420	0.067	0.062
$\frac{3}{4}$ (0.7500)	0.375	0.357	0.523	0.518	0.081	0.076
$\frac{7}{8}$ (0.8750)	0.437	0.418	...	...	...	...
1 (1.0000)	0.500	0.480	...	...	...	...
$1\frac{1}{8}$ (1.1250)	0.562	0.542	...	...	...	...
$1\frac{1}{4}$ (1.2500)	0.625	0.605	...	...	...	...
$1\frac{3}{8}$ (1.3750)	0.687	0.667	...	...	...	...
$1\frac{1}{2}$ (1.5000)	0.750	0.730	...	...	...	...
$1\frac{3}{4}$ (1.7500)	0.875	0.855	...	...	...	...
2 (2.0000)	1.000	0.980	...	...	...	...

## GENERAL NOTES:

- (a) Type A point shown in Fig. 1 is the cup point dimensioned in Table 14. Types B through G are typical variations of the cup point, which is supplied by some manufacturers.
- (b) For dimensions not shown above, refer to Table 14.

**Fig. 1 Cup Point Variations**

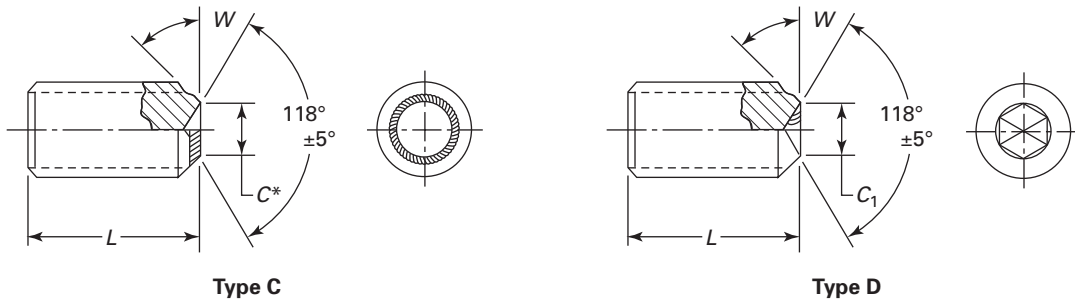
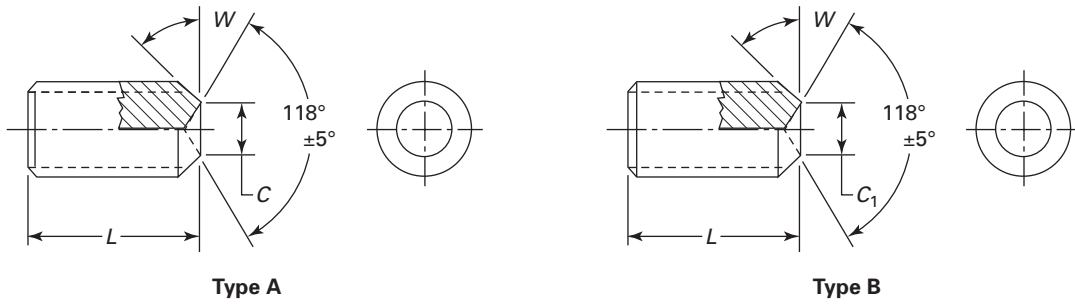

\*This diameter may be counterbored.

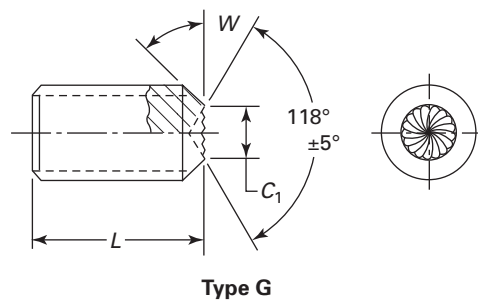
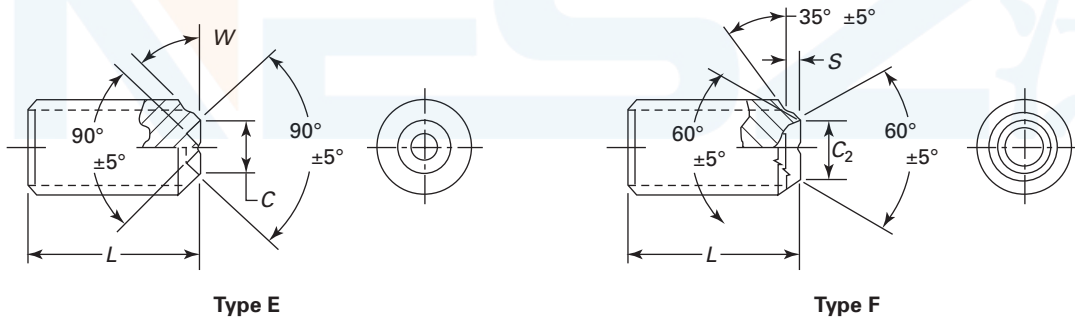

**Table 17 Dimensions of Hexagon Keys and Bits**

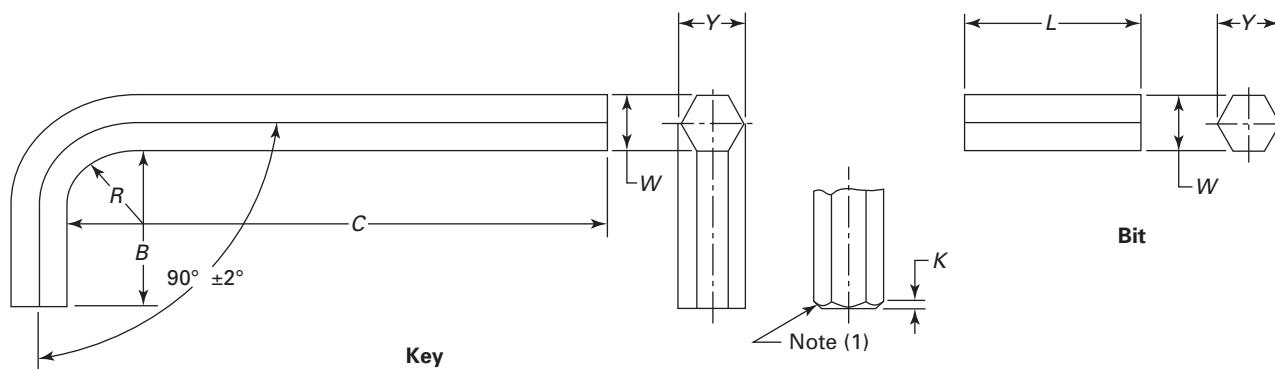

Nominal Key or Bit and Socket Size	Hexagon Width Across Flats, W		Hexagon Width Across Corners, Y		Length, B		Length, C				Minimum Radius of Bend, R	Length of Bit, ±0.062, L	Maximum Chamfer, K	Minimum Torsion Load, in.-lb	
	Max.	Min.	Max.	Min.	Max.	Min.	Short Arm Series		Long Arm Series						
							Max.	Min.	Max.	Min.					
...	0.028	0.0280	0.0275	0.0314	0.0300	0.312	0.125	1.312	1.125	2.688	2.500	0.062	...	0.003	0.94
...	0.035	0.0350	0.0345	0.0393	0.0378	0.438	0.250	1.312	1.125	2.766	2.578	0.062	...	0.004	1.80
...	0.050	0.0500	0.0490	0.0560	0.0540	0.625	0.438	1.750	1.562	2.938	2.750	0.062	...	0.006	5.25
1/16	0.062	0.0625	0.0615	0.0701	0.0680	0.656	0.469	1.844	1.656	3.094	2.906	0.062	...	0.008	10.25
5/64	0.078	0.0781	0.0771	0.0880	0.0859	0.703	0.516	1.969	1.781	3.281	3.094	0.078	...	0.008	20.0
3/32	0.094	0.0937	0.0927	0.1058	0.1035	0.750	0.562	2.094	1.906	3.469	3.281	0.094	...	0.009	35.0
7/64	0.109	0.1094	0.1079	0.1238	0.1210	0.797	0.609	2.219	2.031	3.656	3.469	0.109	...	0.014	55.0
1/8	0.125	0.1250	0.1235	0.1418	0.1390	0.844	0.656	2.344	2.156	3.844	3.656	0.125	...	0.015	82.0
9/64	0.141	0.1406	0.1391	0.1593	0.1566	0.891	0.703	2.469	2.281	4.031	3.844	0.141	...	0.016	118.0
5/32	0.156	0.1562	0.1547	0.1774	0.1745	0.938	0.750	2.594	2.406	4.219	4.031	0.156	...	0.016	160.0
3/16	0.188	0.1875	0.1860	0.2135	0.2105	1.031	0.844	2.844	2.656	4.594	4.406	0.188	...	0.022	278.0
7/32	0.219	0.2187	0.2172	0.2490	0.2460	1.125	0.938	3.094	2.906	4.969	4.781	0.219	...	0.024	440.0
1/4	0.250	0.2500	0.2485	0.2845	0.2815	1.219	1.031	3.344	3.156	5.344	5.156	0.250	...	0.030	665.0
5/16	0.312	0.3125	0.3110	0.3570	0.3531	1.344	1.156	3.844	3.656	6.094	5.906	0.312	...	0.032	1275.0
3/8	0.375	0.3750	0.3735	0.4285	0.4238	1.469	1.281	4.344	4.156	6.844	6.656	0.375	...	0.044	2200.0
7/16	0.438	0.4375	0.4355	0.5005	0.4944	1.594	1.406	4.844	4.656	7.594	7.406	0.438	...	0.047	3500.0
1/2	0.500	0.5000	0.4975	0.5715	0.5650	1.719	1.531	5.344	5.156	8.344	8.156	0.500	...	0.050	5200.0
9/16	0.562	0.5625	0.5600	0.6420	0.6356	1.844	1.656	5.844	5.656	9.094	8.906	0.562	...	0.053	6500.0
5/8	0.625	0.6250	0.6225	0.7146	0.7080	1.969	1.781	6.344	6.156	9.844	9.656	0.625	...	0.055	9000.0
3/4	0.750	0.7500	0.7470	0.8580	0.8512	2.219	2.031	7.344	7.156	11.344	11.156	0.750	...	0.070	15500.0
7/8	0.875	0.8750	0.8720	1.0020	0.9931	2.469	2.281	8.344	8.156	12.844	12.656	0.875	...	0.076	24600.0
1	1.000	1.0000	0.9970	1.1470	1.1350	2.719	2.531	9.344	9.156	14.344	14.156	1.000	...	0.081	28800.0
1 1/4	1.250	1.2500	1.2430	1.4337	1.4138	3.250	2.750	11.500	11.000	...	...	1.250	3.750	0.092	...
1 1/2	1.500	1.5000	1.4930	1.7204	1.6981	3.750	3.250	13.500	13.000	...	...	1.500	4.500	0.104	...
1 3/4	1.750	1.7500	1.7430	2.0072	1.9825	4.250	3.750	15.500	15.000	...	...	1.750	5.250	0.115	...
2	2.000	2.0000	1.9930	2.2939	2.2668	4.750	4.250	17.500	17.000	...	...	2.000	6.000	0.126	...
2 1/4	2.250	2.2500	2.2430	2.5807	2.5511	5.250	4.750	19.500	19.000	...	...	2.250	6.750	0.137	...
2 3/4	2.750	2.7500	2.7420	3.1541	3.1187	6.250	5.750	23.500	23.000	...	...	2.750	8.250	0.159	...
3	3.000	3.0000	2.9920	3.4409	3.4030	6.750	6.250	25.500	25.000	...	...	3.000	9.000	0.171	...

GENERAL NOTE: For additional requirements, refer to Notes (2) through (7).



**Table 17 Dimensions of Hexagon Keys and Bits (Cont'd)**

## NOTES:

- (1) Each end shall be square with the axis of each arm within 4 deg and edges may be sharp or chamfered at the option of the manufacturer. The chamfer shall not exceed the values listed.
- (2) Hexagon keys are furnished as Short Arm Series or Long Arm Series.
- (3) Any truncation or rounding of hexagon corners within the specified across-corner dimensions shall be evident on all corners.
- (4) For nominal socket sizes above 1 in., it is recommended that bits be used in conjunction with standard hexagon wrenches or power drives. When the application makes the use of keys necessary, the keys should conform to the dimensions listed. Bits 1 in. and smaller are available, but the lengths have not been standardized.
- (5) *Material (Steel Alloy)*. Hexagon keys and bits shall be fabricated from an alloy steel having two or more of the following alloying elements: chromium, nickel, molybdenum, or vanadium, in sufficient quantity to ensure that the specified minimum hardness of 48 HRC at the surface for nominal sizes up to and including  $\frac{3}{8}$  in., and 45 HRC for nominal sizes over  $\frac{3}{8}$  in., is met when hexagon keys and bits are hardened by quenching from the austenitizing temperature and tempered.
- (6) For plated hexagon keys and bits, all dimensions are before plating. Because of the high hardness of these products, it is recommended that they not be electroplated.
- (7) *Designation*. To promote uniformity and understanding in communications relating to products conforming to this Standard, it is recommended that hexagon keys or bits be designated in accordance with the following data, preferably in the sequence shown:
  - (a) product name
  - (b) designation of the standard
  - (c) nominal key or bit size
  - (d) series
  - (e) protective finish, if required

## EXAMPLES:

Hexagon Key, ASME B18.3,  $\frac{1}{8}$  Short Arm SeriesHexagon Key, ASME B18.3,  $\frac{1}{8}$  Long Arm Series, Nickel Plated [see Note (6)]Hexagon Key Bit, ASME B18.3,  $1\frac{1}{2}$  Hex

**Table 18 Dimensions of Hexagon Sockets**

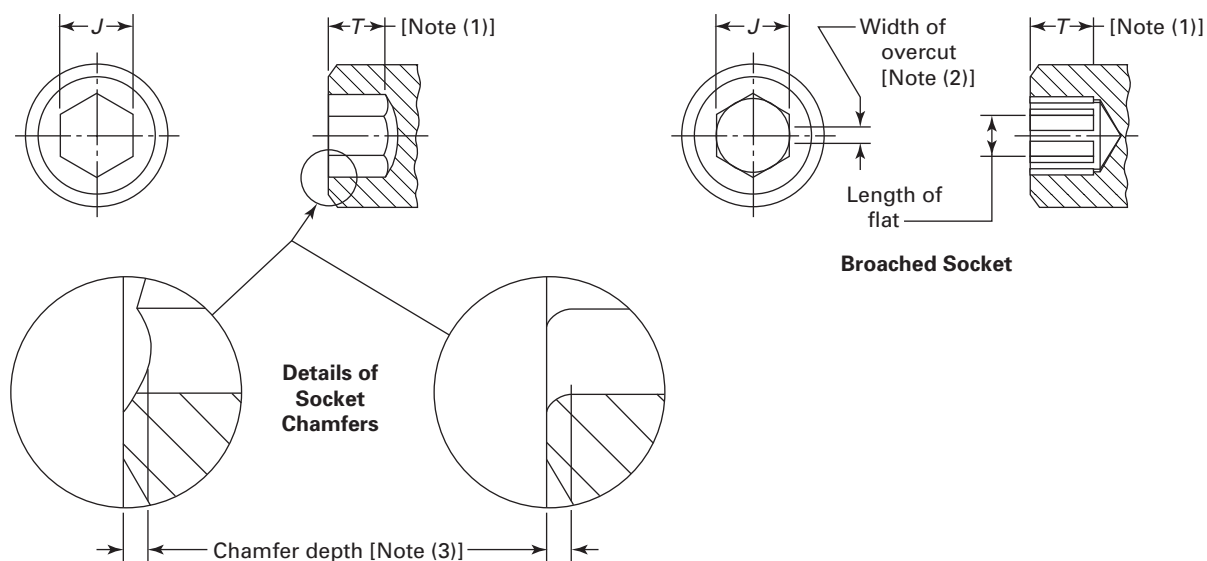

Nominal Socket Size	Socket Width Across Flats, $J$		Nominal Socket Size	Socket Width Across Flats, $J$		Nominal Socket Size	Socket Width Across Flats, $J$				
	Max.	Min.		Max.	Min.		Max.	Min.			
...	0.025	0.0285	0.0280	$\frac{3}{16}$	0.188	0.1900	0.1875	$\frac{7}{8}$	0.875	0.8850	0.8750
...	0.035	0.0355	0.0350	$\frac{7}{32}$	0.219	0.2217	0.2187	1	1.000	1.0200	1.0000
...	0.050	0.0510	0.0500	$\frac{1}{4}$	0.250	0.2530	0.2500	$1\frac{1}{4}$	1.250	1.2750	1.2500
$\frac{1}{16}$	0.062	0.0635	0.0625	$\frac{5}{16}$	0.312	0.3160	0.3125	$1\frac{1}{2}$	1.500	1.5300	1.5000
$\frac{5}{64}$	0.078	0.0791	0.0781	$\frac{3}{8}$	0.375	0.3790	0.3750	$1\frac{3}{4}$	1.750	1.7850	1.7500
$\frac{3}{32}$	0.094	0.0952	0.0937	$\frac{7}{16}$	0.438	0.4420	0.4375	2	2.000	2.0400	2.0000
$\frac{7}{64}$	0.109	0.1111	0.1094	$\frac{1}{2}$	0.500	0.5050	0.5000	$2\frac{1}{4}$	2.250	2.2950	2.2500
$\frac{1}{8}$	0.125	0.1270	0.1250	$\frac{9}{16}$	0.562	0.5680	0.5625	$2\frac{3}{4}$	2.750	2.8050	2.7500
$\frac{9}{64}$	0.141	0.1426	0.1406	$\frac{5}{8}$	0.625	0.6310	0.6250	3	3.000	3.0600	3.0000
$\frac{5}{32}$	0.156	0.1587	0.1562	$\frac{3}{4}$	0.750	0.7570	0.7500	...	...	...	...

**GENERAL NOTES:**

- (a) Sockets up to and including 1 in. nominal size shall be checked in accordance with the hexagon socket gages and gaging specified in Mandatory Appendix I. Suitability of larger sockets shall be determined by means of direct measurement for various technical and economic reasons.
- (b) Dimensions of sockets apply before plating. When plated, see Mandatory Appendix I. (For plated products, see para. 1.7.)
- (c) Broach petals at the bottom of the socket are permissible.
- (d) For additional requirements, refer to section 2, General Data, of this Standard.

**NOTES:**

- (1) Applicable socket depths are specified in the dimensional tables and notes for the respective screw types.
- (2) For broached sockets, the maximum acceptable undercut shall be a size causing an average 20% flat length reduction in the maximum dimension across flat hexagon for socket sizes up to and including 1 in., and 30% for larger sockets. The maximum undercut on any one of the six flats shall not exceed a 40% reduction in flat length for any size socket.
- (3) Where hexagon sockets are chamfered, the depth of chamfer shall not exceed 10% of the nominal socket size for sizes up to and including  $\frac{1}{16}$  in., and 7.5% for larger sizes. For chamfered sockets, it is permissible for the NOT GO socket gage to enter to the depth of chamfer as specified in Mandatory Appendix I.

# MANDATORY APPENDIX I

## GAGES AND GAGING FOR HEXAGON SOCKETS

### I-1 GENERAL

The gages specified herein are intended for use in determining the acceptability of sockets up to and including the 1-in. nominal hexagon socket size. Suitability of hexagon sockets of nominal sizes larger than 1 in. shall be determined by direct measurement for various technical and economic reasons. For dimensions of gages for sockets, see Table I-1.

### I-2 GAGING OF HEXAGON SOCKETS

Hexagon sockets in screws shall allow the GO member of the gage to enter freely to the minimum key engagement depths specified in the dimensional tables for the respective screw types.

For hexagon sockets that are not chamfered, the NOT GO gage member shall not enter any of the three across-flat dimensions of the socket for nominal socket sizes of  $\frac{1}{8}$  in. and larger, and the hexagonal NOT GO gage

member shall not enter the socket for nominal socket sizes smaller than  $\frac{1}{8}$  in.

For chamfered hexagon sockets, the NOT GO gage member shall be permitted to enter only to a depth equivalent to 10% of the nominal socket size for nominal socket sizes up to and including  $\frac{1}{16}$  in., and to 7.5% of the nominal socket sizes for larger sockets.

For coated products, use GO gages identical in design and tolerances to those shown in Table I-1, except having minimum dimensions equal to minimum sizes of keys and bits shown in Table 17.

### I-3 GAGES

Gages shall be made from any grade of steel, through-hardened and tempered to 60 HRC minimum.

The form of hexagonal gage members shall be within the tolerance zone specified. See ASME Y14.5.

The surface roughness on hexagon flats shall be 8  $\mu$ in. (arithmetical average) maximum. See ASME B46.1.

The gage handles shall conform to ASME B47.1.

**Table I-1 Dimensions of Gages for Hexagon Sockets**

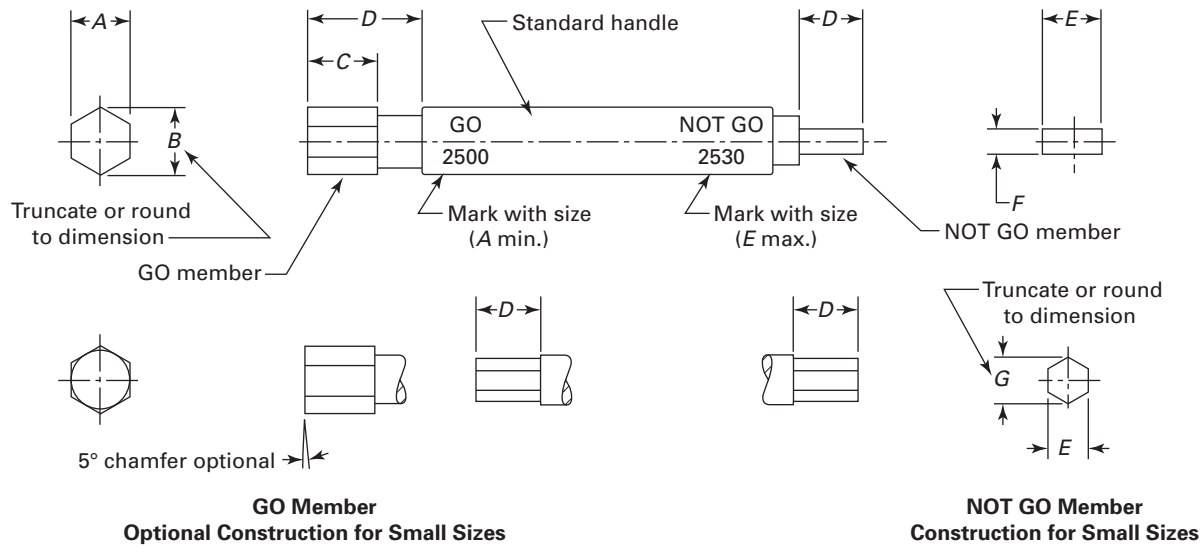

Nominal Socket Size	GO Gage Width Across Flats, A		GO Gage Width Across Corners, B		Minimum GO Gage Length, C	Minimum Usable Gage Length, D	NOT GO Gage Width, E		NOT GO Gage Thickness, F		NOT GO Gage Width Across Corners, G		
	Max.	Min.	Max.	Min.			Max.	Min.	Max.	Min.	Max.	Min.	
...	0.028	0.0281	0.0280	0.0316	0.0314	0.062	0.062	0.0285	0.0284	...	...	0.0308	0.0303
...	0.035	0.0351	0.0350	0.0395	0.0393	0.093	0.093	0.0355	0.0354	...	...	0.0386	0.0381
...	0.050	0.0501	0.0500	0.0562	0.0560	0.187	0.187	0.0510	0.0509	...	...	0.0550	0.0545
1/16	0.062	0.0626	0.0625	0.0703	0.0701	0.187	0.187	0.0635	0.0634	...	...	0.0688	0.0683
5/64	0.078	0.0782	0.0781	0.0882	0.0880	0.187	0.187	0.0791	0.0790	...	...	0.0862	0.0857
3/32	0.094	0.0939	0.0937	0.1060	0.1058	0.250	0.250	0.0952	0.0950	...	...	0.1036	0.1031
7/64	0.109	0.1096	0.1094	0.1240	0.1238	0.250	0.250	0.1111	0.1109	...	...	0.1212	0.1207
1/8	0.125	0.1252	0.1250	0.1420	0.1418	0.250	0.250	0.1270	0.1268	0.057	0.055	...	...
9/64	0.141	0.1408	0.1406	0.1595	0.1593	0.250	0.250	0.1426	0.1424	0.064	0.062	...	...
5/32	0.156	0.1564	0.1562	0.1776	0.1774	0.250	0.250	0.1587	0.1585	0.071	0.069	...	...
3/16	0.188	0.1877	0.1875	0.2137	0.2135	0.250	0.375	0.1900	0.1898	0.088	0.086	...	...
7/32	0.219	0.2189	0.2187	0.2492	0.2490	0.250	0.437	0.2217	0.2215	0.102	0.100	...	...
1/4	0.250	0.2502	0.2500	0.2848	0.2845	0.312	0.500	0.2530	0.2528	0.117	0.115	...	...
5/16	0.312	0.3127	0.3125	0.3573	0.3570	0.312	0.625	0.3160	0.3158	0.150	0.148	...	...
3/8	0.375	0.3752	0.3750	0.4288	0.4285	0.500	0.750	0.3790	0.3788	0.180	0.178	...	...
7/16	0.438	0.4377	0.4375	0.5008	0.5005	0.500	0.875	0.4420	0.4418	0.211	0.209	...	...
1/2	0.500	0.5002	0.5000	0.5718	0.5715	0.500	1.000	0.5050	0.5048	0.241	0.239	...	...
9/16	0.562	0.5627	0.5625	0.6424	0.6420	0.750	1.125	0.5680	0.5678	0.269	0.267	...	...
5/8	0.625	0.6252	0.6250	0.7150	0.7146	0.750	1.250	0.6310	0.6308	0.302	0.300	...	...
3/4	0.750	0.7502	0.7500	0.8585	0.8580	0.750	1.500	0.7570	0.7568	0.364	0.362	...	...
7/8	0.875	0.8752	0.8750	1.0025	1.0020	0.875	1.750	0.8850	0.8848	0.423	0.421	...	...
1	1.000	1.0002	1.0000	1.1475	1.1470	1.000	2.000	1.0100	1.0098	0.489	0.487	...	...

## MANDATORY APPENDIX II

### PROTRUSION GAGING OF FLAT COUNTERSUNK HEADS

#### I-1 PRIMARY METHOD

In case of dispute, the primary methods shall be preferential. Suitability of flat countersunk head screws for application in countersinks designed to the principal dimensions of the screws shall be determined by use of a protrusion gage as illustrated in Fig. II-1. See Table II-1 for the alternate method.

The protrusion dimensions and the gage diameters are specified in Table 8.

To ensure adequate service life, the protrusion gage should be made of tool steel having a hardness of not less than Rockwell C 60 (60 HRC).

If heads meet the original flushness requirements in a flushness gage, as established by ASME B18.3-1986 and prior, they are acceptable and will meet current requirements. The flushness gage must meet, or be more discriminating than the original flushness gage requirement (flush in an 82 deg by "A" diameter countersink). The original flushness tolerances are included for informational purposes only (see Nonmandatory Appendix B).

Fig. II-1 Primary Method

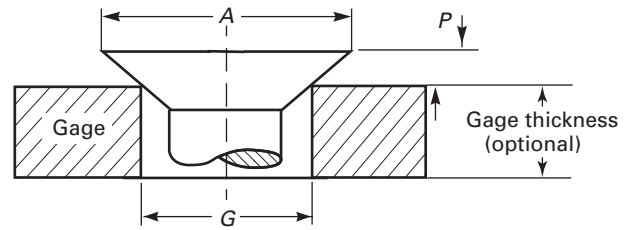
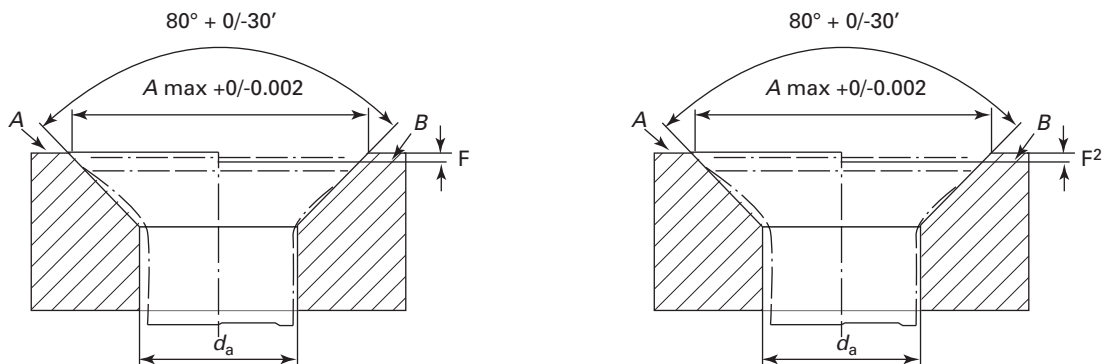

Table II-1 Alternate Method



Nominal Size (Basic Screw Diameter)	$d_a$ Maximum Gage ID	$F^2$ Flushness	
		Max.	Min.
		0 (0.0600)	0.072
1 (0.0730)	0.089	0.0979	0.089
2 (0.0860)	0.106	0.1166	0.106
3 (0.0990)	0.119	0.1309	0.119
4 (0.1120)	0.136	0.1496	0.136
5 (0.1250)	0.153	0.1683	0.153
6 (0.1380)	0.168	0.1848	0.168
8 (0.1640)	0.194	0.2134	0.194
10 (0.1900)	0.22	0.242	0.22
12 (0.2158)	0.246	0.271	0.246
1/4 (0.2500)	0.28	0.308	0.28
5/16 (0.3125)	0.343	0.3773	0.343
3/8 (0.3750)	0.405	0.4455	0.405
7/16 (0.4375)	0.468	0.5148	0.468
1/2 (0.5000)	0.53	0.583	0.53
5/8 (0.6250)	0.655	0.7205	0.655
3/4 (0.7500)	0.78	0.858	0.78
7/8 (0.8750)	0.905	0.9955	0.905
1 (1.0000)	1.03	1.133	1.03
1 1/8 (1.1250)	1.187	1.3057	1.187
1 1/4 (1.2500)	1.312	1.4432	1.312
1 3/8 (1.3750)	1.437	1.5807	1.437
1 1/2 (1.5000)	1.562	1.7182	1.562

## MANDATORY APPENDIX III TYPE VI RECESS DIMENSIONS

See Tables III-1 and III-2.

FINESZ 泛微

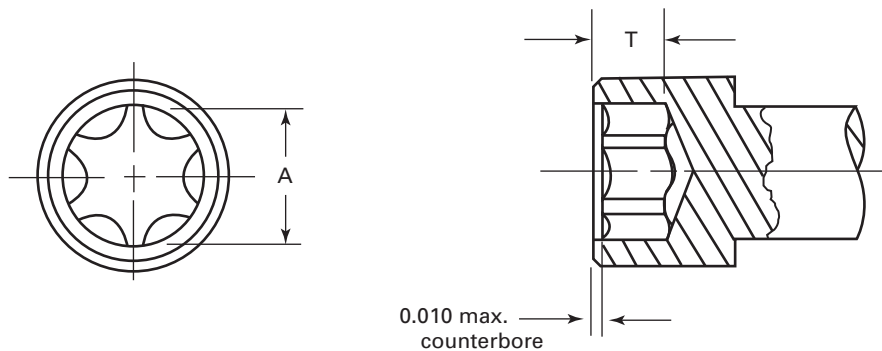
**Table III-1 Recess Reference Size and NOT GO (Fallaway)**

Recess Size	A Ref.	NOT GO (Fallaway) Max. [Note (1)]
T1	0.034	0.000
T2	0.039	0.000
T3	0.047	0.000
T5	0.058	0.009
T6	0.069	0.014
T8	0.094	0.019
T10	0.111	0.022
T15	0.132	0.026
T20	0.155	0.031
T25	0.178	0.036
T27	0.200	0.040
T30	0.221	0.044
T40	0.266	0.047
T45	0.312	0.055
T50	0.352	0.062
T55	0.446	0.078
T60	0.529	0.093
T70	0.619	0.108
T90	0.795	0.139
T100	0.882	0.154

**NOTE:**

- (1) Fallaway is a term that is commonly used amongst fastener manufacturers to indicate the maximum depth that NOT GO recess element can enter a Type VI recess.



Table III-2 Dimensions for Type VI Recess

Nominal Screw Size (Basic Screw Recess Diameter)	Cap Screw		Low Head Cap Screw		Flat Countersunk Head Screw	
	Recess Size	Minimum GO, <i>T</i>	Recess Size	Minimum GO, <i>T</i>	Recess Size	Minimum GO, <i>T</i>
#0 (0.0600)	...	...	...	...	...	...
#1 (0.0730)	...	...	...	...	...	...
#2 (0.0860)	T8	0.033	...	...	T8	0.030
#3 (0.0990)	T8	0.038	...	...	...	...
#4 (0.1120)	T10	0.050	...	...	T10	0.035
#5 (0.1250)	T10	0.050	...	...	T10	0.040
#6 (0.1380)	T15	0.060	...	...	T15	0.040
#8 (0.1640)	T25	0.080	T15	0.040	T20	0.045
#10 (0.1900)	T27	0.085	T20	0.038	T25	0.050
#12 (0.216)	T27	0.085	...	...	...	...
1/4 (0.2500)	T30	0.115	T27	0.055	T30	0.065
5/16 (0.3125)	T45	0.130	T30	0.080	T40	0.087
3/8 (0.3750)	T50	0.166	T40	0.100	T45	0.105
7/16 (0.4375)	T55	0.190	...	...	T50	0.100
1/2 (0.5000)	T55	0.205	T50	0.120	T50	0.119
9/16 (0.5625)	T60	0.230	...	...	...	...
5/8 (0.6250)	T70	0.310	...	...	T55	0.135
3/4 (0.7500)	T90	0.340	...	...	T60	0.205
7/8 (0.8750)	T100	0.430	...	...	T70	0.265
1 (1.0000)	T100	0.490	...	...	T90	0.285

Nominal Screw Size (Basic Screw Recess Diameter)	Button Head Screw		Shoulder Screw		Set Screw	
	Recess Size	Minimum GO, <i>T</i>	Recess Size	Minimum GO, <i>T</i>	Recess Size	Minimum GO, <i>T</i>
#0 (0.0600)	...	...	...	...	T1	0.015
#1 (0.0730)	T5	0.015	...	...	T2	0.015
#2 (0.0860)	T6	0.022	...	...	T3	0.020
#3 (0.0990)	...	...	...	...	T5	0.025
#4 (0.1120)	T8	0.030	...	...	T6	0.030
#5 (0.1250)	T10	0.035	...	...	T7	0.035
#6 (0.1380)	T10	0.035	...	...	T7	0.035
#8 (0.1640)	T15	0.040	...	...	T8	0.043
#10 (0.1900)	T25	0.050	...	...	T10	0.060
1/4 (0.2500)	T27	0.060	T20	0.065	T20	0.084
5/16 (0.3125)	T40	0.090	T27	0.085	T27	0.100
3/8 (0.3750)	T45	0.105	T40	0.115	T30	0.120
7/16 (0.4375)	...	...	...	...	T40	0.130
1/2 (0.5000)	T55	0.140	T45	0.130	T45	0.130
9/16 (0.5625)	...	...	...	...	T50	0.166
5/8 (0.6250)	T60	0.140	T55	0.190	T55	0.205
3/4 (0.7500)	...	...	T60	0.230	T60	0.235
7/8 (0.8750)	...	...	...	...	T70	0.310
1 (1.0000)	...	...	T70	0.265	T70	0.310
1 1/4 (1.2500)	...	...	T90	0.340	...	...

GENERAL NOTE: Recess gages and gaging procedures are in the Appendix of ASME B18.6.3.

# NONMANDATORY APPENDIX A DRILL AND COUNTERBORE SIZES FOR SOCKET HEAD CAP SCREWS

See Table A-1.

FINESZ 泛微

**Table A-1 Drill and Counterbore Sizes for Socket Head Cap Screws**

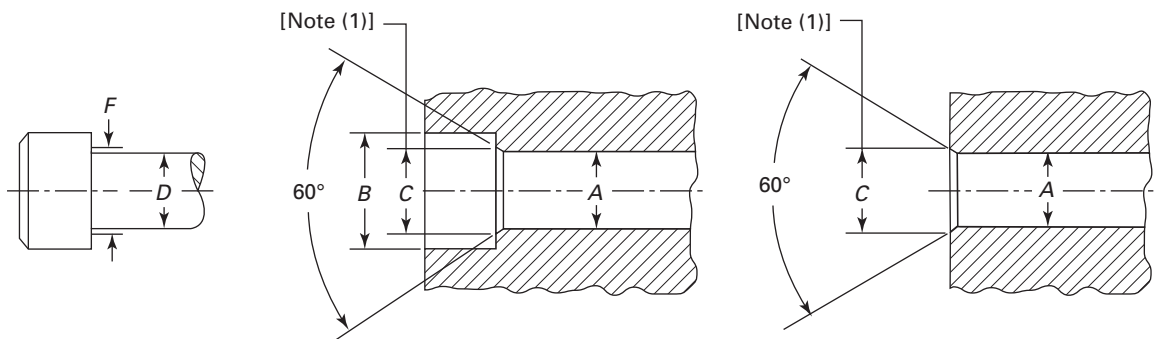

Nominal Size (Basic Screw Diameter)	Nominal Drill Size, A				Counterbore Diameter, B	Countersink, C [Note (1)]
	Close Fit [Note (2)]		Normal Fit [Note (3)]			
	Number or Fractional Size	Decimal Size	Number or Fractional Size	Decimal Size		
0 (0.0600)	51	0.067	49	0.073	1/8	0.074
1 (0.0730)	46	0.081	43	0.089	5/32	0.087
2 (0.0860)	3/32	0.094	36	0.106	3/16	0.102
3 (0.0990)	36	0.106	31	0.120	7/32	0.115
4 (0.1120)	1/8	0.125	29	0.136	7/32	0.130
5 (0.1250)	9/64	0.141	23	0.154	1/4	0.145
6 (0.1380)	23	0.154	18	0.170	9/32	0.158
8 (0.1640)	15	0.180	10	0.194	5/16	0.188
10 (0.1900)	5	0.206	2	0.221	3/8	0.218
12 (0.2160)	15/64	0.234	1/4	0.250	13/32	0.244
1/4 (0.2500)	17/64	0.266	9/32	0.281	7/16	0.278
5/16 (0.3125)	21/64	0.328	11/32	0.344	17/32	0.346
3/8 (0.3750)	25/64	0.391	13/32	0.406	5/8	0.415
7/16 (0.4375)	29/64	0.453	15/32	0.469	23/32	0.483
1/2 (0.5000)	33/64	0.516	17/32	0.531	13/16	0.552
9/16 (0.5625)	37/64	0.578	19/32	0.594	29/32	0.615
5/8 (0.6250)	41/64	0.641	21/32	0.656	1	0.689
3/4 (0.7500)	49/64	0.766	25/32	0.781	1 3/16	0.828
7/8 (0.8750)	57/64	0.891	29/32	0.906	1 3/8	0.963
1 (1.0000)	1 1/64	1.016	1 1/32	1.031	1 5/8	1.100
1 1/4 (1.2500)	1 9/32	1.281	1 3/16	1.312	2	1.370
1 1/2 (1.5000)	1 17/32	1.531	1 9/16	1.562	2 3/8	1.640
1 3/4 (1.7500)	1 25/32	1.781	1 13/16	1.812	2 3/4	1.910
2 (2.0000)	2 1/32	2.031	2 1/16	2.062	3 1/8	2.180

**Table A-1 Drill and Counterbore Sizes for Socket Head Cap Screws (Cont'd)**

## NOTES:

- (1) *Countersink*. It is considered good practice to countersink or break the edges of holes that are smaller than  $F$  (max.) (see Tables 2 and 3) in parts having a hardness which approaches, equals, or exceeds the screw hardness. If such holes are not countersunk, the heads of screws may not seat properly or the sharp edges on holes may deform the fillets on screws thereby making them susceptible to fatigue in applications involving dynamic loading. The countersink or corner relief, however, should not be larger than is necessary to insure that the fillet on the screw is cleared. Normally, the diameter of countersink does not have to exceed  $F$  (max.) (see Tables 2 and 3). Countersinks or corner reliefs in excess of this diameter reduce the effective bearing area and introduce the possibility of imbedment where the parts to be fastened are softer than the screws or brinelling or flaring of the heads of the screws where the parts to be fastened are harder than the screws.
- (2) *Close Fit*. The close fit is normally limited to holes for those lengths of screws that are threaded to the head (see Table 4) in assemblies where only one screw is to be used or where two or more screws are to be used and the mating holes are to be produced either at assembly or by matched and coordinated tooling.
- (3) *Normal Fit*. The normal fit is intended for screws of relatively long length or for assemblies involving two or more screws where the mating holes are to be produced by conventional tolerancing methods. It provides for the maximum allowable eccentricity of the longest standard screws and for certain variations in the parts to be fastened, such as: deviations in hole straightness, angularity between the axis of the tapped hole and that of the hole for the shank, differences in center distances of the mating holes, etc.

FINESZ 泛微

## NONMANDATORY APPENDIX B FORMULAS FOR DIMENSIONS

### B-1 HEXAGON SOCKET HEAD CAP SCREWS

(a) *Body Diameter, D, Table 1*

$D$  (max.) = basic or nominal size (see Table 1 for values)

$D$  (min.) = minimum major diameter Class 3A UNRF threads for sizes 0 in. through 1 in.

= minimum major diameter Class 3A UNRC threads for sizes over 1 in.

(b) *Head Diameter, A, Table 1*

$A$  (max.) = see Table 1 for value for sizes 0 in. through 10 in.

=  $1.50D$  (max.) for sizes  $\frac{1}{4}$  in. through 4 in.

$A$  (min.) =  $A$  (max.) -  $0.021 \sqrt{D}$  (max.)

(c) *Head Height, H, Table 1*

$H$  (max.) =  $D$  (max.)

$H$  (min.) =  $H$  (max.) -  $0.012 \sqrt{D}$  (max.)

(d) *Key Engagement, T, Table 1*

$T$  (min.) =  $0.50H$  (max.) - 0.005

(e) *Wall Thickness, G, Table 1*

$G$  (min.) =  $0.34H$  (max.) for sizes 0 in. through 10 in.

=  $0.38H$  (max.) for sizes  $\frac{1}{4}$  in. through 4 in.

### B-2 HEXAGON SOCKET FLAT COUNTERSUNK HEAD CAP SCREWS

(a) *Body Diameter, D, Table 8*

$D$  (max.) = basic or nominal size (see Table 8 for values)

$D$  (min.) = minimum major diameter Class 3A UNRF threads for sizes 0 in. through 1 in.

= minimum major diameter Class 3A UNRC threads for sizes over 1 in.

(b) *Head Diameter, A, Table 8*

$A$  (max.)

Theor. Sharp = no formula for sizes 0 in. through 3 in. (see Table 8 for values)

=  $2D$  (max.) + 0.031 for sizes 4 in. through  $\frac{3}{8}$  in.

=  $2D$  (max.) - 0.031 for  $\frac{7}{16}$  in. size

=  $2D$  (max.) - 0.062 for sizes  $\frac{1}{2}$  in. through  $1\frac{1}{2}$  in.

(c) *Maximum Head Height, H, Table 8*

$$H_{\max} \text{ (ref.)} = \frac{A \text{ (max.)} - D \text{ (max.)}}{2} \cot 41 \text{ deg}$$

(d) *Head Protrusion, Table 8.* No formula (See Table 8 for values).

(e) *Original Flushness Tolerance.* Prior to ASME B18.3-1998

Nominal Size		Flushness Tolerance
0	(0.0600)	0.006
1	(0.0730)	0.007
2	(0.0860)	0.008
3	(0.0990)	0.010
4	(0.1120)	0.011
5	(0.1250)	0.012
6	(0.1380)	0.013
8	(0.1640)	0.014
10	(0.1900)	0.015
$\frac{1}{4}$	(0.2500)	0.016
$\frac{5}{16}$	(0.3125)	0.017
$\frac{3}{8}$	(0.3750)	0.018
$\frac{7}{16}$	(0.4375)	0.018
$\frac{1}{2}$	(0.5000)	0.018
$\frac{5}{8}$	(0.6250)	0.022
$\frac{3}{4}$	(0.7500)	0.024
$\frac{7}{8}$	(0.8750)	0.025
1	(1.0000)	0.028
$1\frac{1}{8}$	(1.1250)	0.031
$1\frac{1}{4}$	(1.2500)	0.035
$1\frac{3}{8}$	(1.3750)	0.038
$1\frac{1}{2}$	(1.5000)	0.042

(f) *Key Engagement, T (min.), Table 8*

$T$  (min.) =  $0.68H - 0.005$  for sizes 0 in. through 3 in.

=  $0.68H$  for sizes over 3 in. through  $\frac{5}{8}$  in.

=  $0.53H$  approximately for sizes  $\frac{3}{4}$  in. through  $1\frac{1}{2}$  in.

### B-3 HEXAGON SOCKET BUTTON HEAD CAP SCREWS

(a) *Head Diameter, A, Table 11*

$A$  (max.)<sup>1</sup> =  $1.90D$  for sizes 0 in. through 10 in.

=  $1.75D$  for sizes  $\frac{1}{4}$  in. through  $\frac{1}{2}$  in.

=  $1.60D$  for  $\frac{5}{8}$ -in. size

=  $1.50D$  for  $\frac{3}{4}$ -in. size

<sup>1</sup> Where  $D$  is the basic diameter of screw.

- (b) *Head Height, H, Table 11*  
 $H (\text{max.})^1 = 0.53D (\text{min.})$

- (c) *Key Engagement, T (min.), Table 11*  
 $T (\text{min.}) = 0.56J (\text{min.})$

#### B-4 HEXAGON SOCKET HEAD SHOULDER SCREWS

- (a) *Shoulder Diameter, D, Table 13*  
 $D (\text{max.}) = \text{nominal size} - 0.002$   
 $D (\text{min.}) = D (\text{max.}) - 0.002$
- (b) *Head Diameter, A, Table 13*  
 $A (\text{max.}) = \text{no formula (see Table 13 for values)}$   
 $A (\text{min.}) = \text{no formula (see Table 13 for values)}$
- (c) *Head Height, H, Table 13*  
 $H (\text{max.}) = 0.50 (\text{nominal size}) + 0.0625$  for sizes  
 $\frac{1}{4}$  in. through  $\frac{5}{8}$  in.  
 $= 0.50 (\text{nominal size}) + 0.125$  for sizes  
 $\frac{3}{4}$  in. through  $1\frac{1}{4}$  in.
- (d) *Thread Neck Width, I, Table 13*  
 $I (\text{max.}) = 2.00$  UNC thread pitches

#### B-5 HEXAGON SOCKET SET SCREWS

- (a) *Key Engagement,  $T_H$  and  $T_S$ , Table 14*  
 $T_H (\text{min.}) = \text{no formula for sizes 0 in. through}$   
 $10 \text{ in. (see Table 14 for values)}$   
 $= J (\text{nom.})$  for sizes  $\frac{1}{8}$  in. through 2 in.
- (b) *Oval Point Radius, R, Table 14*  
 $R (\text{basic})^1 = 0.75D$
- (c) *Half Dog Point Length, Q, Table 14*  
 $Q (\text{basic})^1 = 0.25D$
- (d) *Half Dog Point Diameter, P, Table 14*  
 $P (\text{max.})^1 = 0.667D$  for sizes 0 in. through 10 in.  
 $= 0.75D - 0.031$  for sizes  $\frac{1}{4}$  in.  
 through  $\frac{1}{2}$  in.  
 $= 0.75D$  for sizes  $\frac{5}{8}$  in. through 2 in.

#### B-6 HEXAGON KEYS

- Radius of Bend, R, Table 17*  
 $R (\text{min.}) = \text{no formula (see Table 17 for key sizes}$   
 $0.028 \text{ through } 0.050)$   
 $= W (\text{max.})$  for key sizes  $\frac{1}{16}$  in. through  
 1 in.

## **NONMANDATORY APPENDIX C HEXAGON SOCKET HEAD CAP SCREWS (1936 SERIES)**

Prior to 1961, the 1936 Series of socket head cap screws were recognized as standard. The 1936 Series screws are no longer stocked by screw manufacturers and are now available only on special order. The major differences between the 1936 Series screws and the present standard screws (1960 Series) are that, for some sizes, the 1936 Series had smaller head diameters and/or socket sizes and/or different thread lengths. Users desiring additional information on the 1936 Series should refer to Appendix IV of ASA B18.3-1961, or should consult socket screw manufacturers.

In the event of an order, unless otherwise specified, the manufacturer may use the thread length and length tolerances for 1960 Series style Socket Cap Screws on 1936 Series style Socket Cap Screws.

FINESZ 泛微

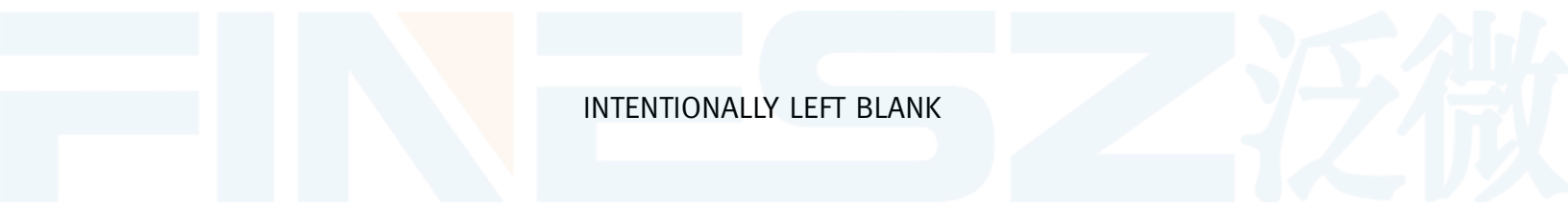

INTENTIONALLY LEFT BLANK



# B18 AMERICAN NATIONAL STANDARDS FOR BOLTS, NUTS, RIVETS, SCREWS, WASHERS, AND SIMILAR FASTENERS

Small Solid Rivets .....	B18.1.1-1972 (R2011)
Large Rivets .....	B18.1.2-1972 (R2011)
Metric Small Solid Rivets .....	B18.1.3M-1983 (R2011)
Square, Hex, Heavy Hex, and Askew Head Bolts and Hex, Heavy Hex, Hex Flange, Lobed Head, and Lag Screws (Inch Series) .....	B18.2.1-2010
Nuts for General Applications: Machine Screw Nuts, Hex, Square, Hex Flange, and Coupling Nuts (Inch Series) .....	B18.2.2-2010
Metric Hex Cap Screws .....	B18.2.3.1M-1999 (R2011)
Metric Formed Hex Screws .....	B18.2.3.2M-2005
Metric Heavy Hex Screws .....	B18.2.3.3M-1979 (R2001)
Metric Hex Flange Screws .....	B18.2.3.4M-2001 (R2011)
Metric Hex Bolts .....	B18.2.3.5M-1979 (R2011)
Metric Heavy Hex Bolts .....	B18.2.3.6M-1979 (R2006)
Metric Heavy Hex Flange Screws .....	B18.2.3.9M-2001 (R2006)
Metric Slotted Hex Nuts .....	B18.2.4.3M-1979 (R2012)
Metric Flanged 12-Point Head Screws .....	B18.2.5M-2009
Metric Fasteners for Use in Structural Applications .....	B18.2.6M-2012
Clearance Holes for Bolt, Screws, and Studs .....	B18.2.8-1999 (R2010)
Straightness Gage and Gaging for Bolts and Screws .....	B18.2.9-2010
Socket Cap, Shoulder, Set Screws, and Hex Keys (Inch Series) .....	B18.3-2012 (R2008)
Socket Head Cap Screws (Metric Series) .....	B18.3.1M-1986 (R2008)
Metric Series Hexagon Keys and Bits .....	B18.3.2M-1979 (R2008)
Hexagon Socket Head Shoulder Screws (Metric Series) .....	B18.3.3M-1986 (R2008)
Hexagon Socket Button Head Cap Screws (Metric Series) .....	B18.3.4M-1986 (R2008)
Hexagon Socket Flat Countersunk Head Cap Screws (Metric Series) .....	B18.3.5M-1986 (R2008)
Metric Series Socket Set Screws .....	B18.3.6M-1986 (R2008)
Round Head Bolts (Inch Series) .....	B18.5-2008
Metric Round Head Short Square Neck Bolts .....	B18.5.2.1M-2006 (R2011)
Metric Round Head Square Neck Bolts .....	B18.5.2.2M-1982 (R2010)
Wood Screws (Inch Series) .....	B18.6.1-1981 (R2008)
Slotted Head Cap Screws, Square Head Set Screws, and Slotted Headless Set Screws (Inch Series) .....	B18.6.2-1998 (R2010)
Machine Screws, Tapping Screws, and Metallic Drive Screws (Inch Series) .....	B18.6.3-2010
Thread-Forming and Thread-Cutting Tapping Screws and Metallic Drive Screws (Inch Series) .....	B18.6.4-1998 (R2005)
Metric Thread-Forming and Thread-Cutting Tapping Screws .....	B18.6.5M-2000 (R2010)
Metric Machine Screws .....	B18.6.7M-1999 (R2010)
Thumb Screws and Wing Screws (Inch Series) .....	B18.6.8-2010
Wing Nuts (Inch Series) .....	B18.6.9-2010
General Purpose Semi-Tubular Rivets, Full Tubular Rivets, Split Rivets and Rivet Caps .....	B18.7-2007 (R2012)
Metric General Purpose Semi-Tubular Rivets .....	B18.7.1M-2007 (R2012)
Clevis Pins and Cotter Pins (Inch Series) .....	B18.8.1-1994 (R2010)
Taper Pins, Dowel Pins, Straight Pins, Grooved Pins, and Spring Pins (Inch Series) .....	B18.8.2-2000 (R2010)
Spring Pins: Coiled Type, Spring Pins: Slotted, Machine Dowel Pins: Hardened Ground, and Grooved Pins (Metric Series) .....	B18.8.100M-2000 (R2010)
Cotter Pins, Headless Clevis Pins, and Headed Clevis Pins (Metric Series) .....	B18.8.200M-2000 (R2010)
Plow Bolts .....	B18.9-2012
Track Bolts and Nuts .....	B18.10-2006 (R2011)
Miniature Screws .....	B18.11-1961 (R2010)
Glossary of Terms for Mechanical Fasteners .....	B18.12-2012
Screw and Washer Assemblies — Sems (Inch Series) .....	B18.13-1996 (R2008)
Screw and Washer Assemblies: SEMS (Metric Series) .....	B18.13.1M-2011
Forged Eyebolts .....	B18.15-1985 (R2008)
Prevailing-Torque Type Steel Metric Hex Nuts and Hex Flange Nuts .....	B18.16M-2004 (R2009)
Serrated Hex Flange Locknuts 90,000 psi (Inch Series) .....	B18.16.4-2008
Nylon Insert Locknuts (Inch Series) .....	B18.16.6-2008
Quality Assurance for Fasteners .....	B18.18-2011
Inspection and Quality Assurance for General Purpose Fasteners .....	B18.18.1-2007
Inspection and Quality Assurance for High-Volume Machine Assembly Fasteners .....	B18.18.2-2009
Inspection and Quality Assurance for Special Purpose Fasteners .....	B18.18.3M-1987 (R2005)
Inspection and Quality Assurance for Fasteners for Highly Specialized Engineered Applications .....	B18.18.4M-1987 (R2005)

Inspection and Quality Assurance Plan Requiring In-Process Inspection and Controls.....	B18.18.5M-1998 (R2009)
Quality Assurance Plan for Fasteners Produced in a Third Party Accreditation System .....	B18.18.6M-1998 (R2009)
Quality Assurance Plan for Fasteners Produced in a Customer Approved Control Plan .....	B18.18.7M-1998 (R2009)
Washers: Helical Spring-Lock, Tooth Lock, and Plain Washers (Inch Series).....	B18.21.1-2009
Lock Washers (Metric Series) .....	B18.21.2M-1999 (R2005)
Double Coil Helical Spring Lock Washers for Wood Structures .....	B18.21.3-2008
Metric Plain Washers.....	B18.22M-1981 (R2010)
Part Identifying Number (PIN) Code System for B18 Fastener Products .....	B18.24-2004
Square and Rectangular Keys and Keyways.....	B18.25.1M-1996 (R2008)
Woodruff Keys and Keyways .....	B18.25.2M-1996 (R2008)
Square and Rectangular Keys and Keyways: Width Tolerances and Deviations Greater Than Basic Size .....	B18.25.3M-1998 (R2008)
Tapered and Reduced Cross Section Retaining Rings (Inch Series) .....	B18.27-1998 (R2011)
Helical Coil Screw Thread Inserts — Free Running and Screw Locking (Inch Series).....	B18.29.1-2010
Helical Coil Screw Thread Inserts: Free Running and Screw Locking (Metric Series) .....	B18.29.2M-2005 (R2010)
Open-End Blind Rivets With Break Mandrels (Metric Series) .....	B18.30.1M-2000 (R2010)
Metric Continuous and Double-End Studs.....	B18.31.1M-2008
Continuous and Double-End Studs.....	B18.31.2-2008
Threaded Rods (Inch Series).....	B18.31.3-2009
Threaded Rod (Metric Series).....	B18.31.4M-2009
Bent Bolts (Inch Series) .....	B18.31.5-2011

The ASME Publications Catalog shows a complete list of all the Standards published by the Society. For a complimentary catalog, or the latest information about our publications, call 1-800-THE-ASME (1-800-843-2763).



# FINESZ 泛微

INTENTIONALLY LEFT BLANK

# ASME B18.3-2012

FINESZ 泛微

ISBN 978-0-7918-3483-1



9 780791 834831



M00712