**Hexagon thin nuts chamfered (style 0) —
Product grades A and B**

Écrous bas hexagonaux chanfreinés (style 0) — Grades A et B



Reference number
ISO 4035:2012(E)

© ISO 2012



COPYRIGHT PROTECTED DOCUMENT

© ISO 2012

All rights reserved. Unless otherwise specified, no part of this publication may be reproduced or utilized in any form or by any means, electronic or mechanical, including photocopying and microfilm, without permission in writing from either ISO at the address below or ISO's member body in the country of the requester.

ISO copyright office
Case postale 56 • CH-1211 Geneva 20
Tel. + 41 22 749 01 11
Fax + 41 22 749 09 47
E-mail copyright@iso.org
Web www.iso.org

Published in Switzerland

Contents	Page
Foreword	iv
Introduction	v
1 Scope	1
2 Normative references	1
3 Dimensions	1
4 Requirements and reference International Standards	4
5 Designation	4
Bibliography	5

Foreword

ISO (the International Organization for Standardization) is a worldwide federation of national standards bodies (ISO member bodies). The work of preparing International Standards is normally carried out through ISO technical committees. Each member body interested in a subject for which a technical committee has been established has the right to be represented on that committee. International organizations, governmental and non-governmental, in liaison with ISO, also take part in the work. ISO collaborates closely with the International Electrotechnical Commission (IEC) on all matters of electrotechnical standardization.

International Standards are drafted in accordance with the rules given in the ISO/IEC Directives, Part 2.

The main task of technical committees is to prepare International Standards. Draft International Standards adopted by the technical committees are circulated to the member bodies for voting. Publication as an International Standard requires approval by at least 75 % of the member bodies casting a vote.

Attention is drawn to the possibility that some of the elements of this document may be the subject of patent rights. ISO shall not be held responsible for identifying any or all such patent rights.

ISO 4035 was prepared by Technical Committee ISO/TC 2, *Fasteners*, Subcommittee SC 12, *Fasteners with metric internal thread*.

This fourth edition cancels and replaces the third edition (ISO 4035:1999), of which it constitutes a minor revision.

Introduction

This International Standard belongs to a complete group of product standards developed by ISO on external hexagon drive fasteners. It comprises the following:

- a) hexagon head bolts (ISO 4014, ISO 4015, ISO 4016 and ISO 8765);
- b) hexagon head screws (ISO 4017, ISO 4018 and ISO 8676);
- c) hexagon nuts (ISO 4032, ISO 4033, ISO 4034, ISO 4035, ISO 4036, ISO 7040, ISO 7041, ISO 7042, ISO 7719, ISO 7720, ISO 8673, ISO 8674, ISO 8675, ISO 10511, ISO 10512 and ISO 10513);
- d) hexagon bolts with flange (ISO 4162, ISO 15071 and ISO 15072);
- e) hexagon nuts with flange (ISO 4161, ISO 7043, ISO 7044, ISO 10663, ISO 12125, ISO 12126 and ISO 21670).

Hexagon thin nuts chamfered (style 0) — Product grades A and B

1 Scope

This International Standard specifies the characteristics of chamfered hexagon thin nuts (style 0), with threads from M1,6 up to and including M64, with product grade A for threads $D \leq M16$ and product grade B for threads $D > M16$.

If, in special cases, specifications other than those listed in this International Standard are required, they can be selected from existing International Standards, for example ISO 724, ISO 898-2, ISO 965-1, ISO 3506-2 and ISO 4759-1.

2 Normative references

The following documents, in whole or in part, are normatively referenced in this document and are indispensable to its application. For undated references, the latest edition of the referenced document (including any amendments) applies.

ISO 225, *Fasteners — Bolts, screws, studs and nuts — Symbols and descriptions of dimensions*

ISO 724, *ISO general-purpose metric screw threads — Basic dimensions*

ISO 898-2, *Mechanical properties of fasteners made of carbon steel and alloy steel — Part 2: Nuts with specified property classes — Coarse thread and fine pitch thread*

ISO 965-1, *ISO general-purpose metric screw threads — Tolerances — Part 1: Principles and basic data*

ISO 3269, *Fasteners — Acceptance inspection*

ISO 3506-2, *Mechanical properties of corrosion-resistant stainless steel fasteners — Part 2: Nuts*

ISO 4042, *Fasteners — Electroplated coatings*

ISO 4759-1, *Tolerances for fasteners — Part 1: Bolts, screws, studs and nuts — Product grades A, B and C*

ISO 6157-2, *Fasteners — Surface discontinuities — Part 2: Nuts*

ISO 8839, *Mechanical properties of fasteners — Bolts, screws, studs and nuts made of non-ferrous metals*

ISO 8992, *Fasteners — General requirements for bolts, screws, studs and nuts*

ISO 10683, *Fasteners — Non-electrolytically applied zinc flake coatings*

ISO 10684, *Fasteners — Hot dip galvanized coatings*

3 Dimensions

See Figure 1 and Tables 1 and 2.

Symbols and descriptions of dimensions are specified in ISO 225.

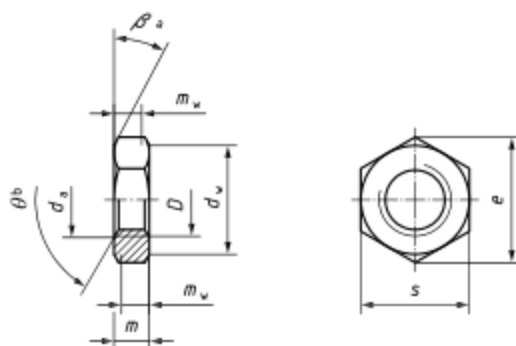

a $\beta = 15^\circ$ to 30° .

b $\theta = 110^\circ$ to 120° .

Figure 1

Table 1 — Preferred threads

Dimensions in millimetres

Thread D		M1,6	M2	M2,5	M3	M4	M5	M6	M8	M10	M12
p^a		0,35	0,4	0,45	0,5	0,7	0,8	1	1,25	1,5	1,75
d_a	max.	1,84	2,30	2,90	3,45	4,60	5,75	6,75	8,75	10,80	13,00
	min.	1,60	2,00	2,50	3,00	4,00	5,00	6,00	8,00	10,00	12,00
d_w	min.	2,40	3,10	4,1	4,60	5,90	6,90	8,90	11,60	14,60	16,60
e	min.	3,41	4,32	5,45	6,01	7,66	8,79	11,05	14,38	17,77	20,03
m	max.	1,00	1,20	1,60	1,80	2,20	2,70	3,20	4,00	5,00	6,00
	min.	0,75	0,95	1,35	1,55	1,95	2,45	2,90	3,70	4,70	5,70
m_w	min.	0,60	0,80	1,10	1,20	1,60	2,00	2,3	3,0	3,8	4,60
s	nom. = max.	3,20	4,00	5,00	5,50	7,00	8,00	10,00	13,00	16,00	18,00
	min.	3,02	3,82	4,82	5,32	6,78	7,78	9,78	12,73	15,73	17,73

Table 1 (continued)

Dimensions in millimetres

Thread <i>D</i>		M16	M20	M24	M30	M36	M42	M48	M56	M64
p^a		2	2,5	3	3,5	4	4,5	5	5,5	6
d_a	max.	17,30	21,60	25,90	32,40	38,90	45,40	51,80	60,50	69,10
	min.	16,00	20,00	24,00	30,00	36,00	42,00	48,00	56,00	64,00
d_w	min.	22,50	27,70	33,20	42,80	51,10	60,00	69,50	78,70	88,20
e	min.	26,75	32,95	39,55	50,85	60,79	71,30	82,60	93,56	104,86
m	max.	8,00	10,00	12,00	15,00	18,00	21,00	24,00	28,00	32,00
	min.	7,42	9,10	10,90	13,90	16,90	19,70	22,70	26,70	30,40
m_w	min.	5,90	7,30	8,70	11,10	13,50	15,80	18,20	21,40	24,30
s	nom. = max.	24,00	30,00	36,00	46,00	55,00	65,00	75,00	85,00	95,00
	min.	23,67	29,16	35,00	45,00	53,80	63,10	73,10	82,80	92,80

^a P is the pitch of the thread.

Table 2 — Non-preferred threads

Dimensions in millimetres

Thread <i>D</i>		M3,5	M14	M18	M22	M27	M33	M39	M45	M52	M60
p^a		0,6	2	2,5	2,5	3	3,5	4	4,5	5	5,5
d_a	max.	4,00	15,10	19,50	23,70	29,10	35,60	42,10	48,60	56,20	64,80
	min.	3,50	14,00	18,00	22,00	27,00	33,00	39,00	45,00	52,00	60,00
d_w	min.	5,10	19,60	24,90	31,40	38,00	46,60	55,90	64,70	74,20	83,40
e	min.	6,58	23,36	29,56	37,29	45,20	55,37	66,44	76,95	88,25	99,21
m	max.	2,00	7,00	9,00	11,00	13,50	16,50	19,50	22,50	26,00	30,00
	min.	1,75	6,42	8,42	9,90	12,40	15,40	18,20	21,20	24,70	28,70
m_w	min.	1,40	5,10	6,70	7,90	9,90	12,30	14,60	17,00	19,80	23,00
s	nom. = max.	6,00	21,00	27,00	34,00	41,00	50,00	60,00	70,00	80,00	90,00
	min.	5,82	20,67	26,16	33,00	40,00	49,00	58,80	68,10	78,10	87,80

^a P is the pitch of the thread.

4 Requirements and reference International Standards

See Table 3.

Table 3 — Requirements and reference International Standards

Material		Steel	Stainless steel	Non-ferrous metal
General requirements	International Standard	ISO 8992		
	Tolerance class	6H		
Thread	International Standards	ISO 724, ISO 965-1		
	Property class	$D < M5$: as agreed $M5 \leq D \leq M39$: 04, 05 $D > M39$: as agreed	$D \leq M24$: A2-035, A4-035 $M24 < D \leq M39$: A2-025, A4-025 $D > M39$: as agreed	Materials specified in ISO 8839
Mechanical properties	International Standards $D < M5$: as agreed $M5 \leq D \leq M39$: ISO 898-2 $D > M39$: as agreed (specified in ISO 898-2:2012, Annex A)	$D \leq M39$: ISO 3506-2 $D > M39$: as agreed		
Tolerance	Product grade	$D \leq M16$: A $D > M16$: B		
	International Standard	ISO 4759-1		
Finish — Coating		As processed Requirements for electroplating are specified in ISO 4042. Requirements for non-electrolytically applied zinc flake coatings are specified in ISO 10683. Requirements for hot dip galvanized coatings are specified in ISO 10684. Additional requirements or other finishes or coatings shall be agreed between the supplier and the purchaser.	Clean and bright A method for passivation is specified in ISO 16048.	As processed Requirements for electroplating are specified in ISO 4042.
Surface integrity		Limits for surface discontinuities are specified in ISO 6157-2		
Acceptability		Acceptance inspection is specified in ISO 3269.		

5 Designation

EXAMPLE A chamfered hexagon thin nut (style 0) with thread M12 and property class 05 is designated as follows:

Hexagon thin nut ISO 4035 - M12 - 05

Bibliography

- [1] ISO 4014, *Hexagon head bolts — Product grades A and B*
- [2] ISO 4015, *Hexagon head bolts — Product grade B — Reduced shank (shank diameter approximately equal to pitch diameter)*
- [3] ISO 4016, *Hexagon head bolts — Product grade C*
- [4] ISO 4017, *Hexagon head screws — Product grades A and B*
- [5] ISO 4018, *Hexagon head screws — Product grade C*
- [6] ISO 4032, *Hexagon regular nuts (style 1) — Product grades A and B*
- [7] ISO 4033, *Hexagon high nuts (style 2) — Product grades A and B*
- [8] ISO 4034, *Hexagon regular nuts (style 1) — Product grade C*
- [9] ISO 4036, *Hexagon thin nuts unchamfered (style 0) — Product grade B*
- [10] ISO 4161, *Hexagon nuts with flange, style 2 — Coarse thread*
- [11] ISO 4162, *Hexagon flange bolts — Small series — Product grade A with driving feature of product grade B*
- [12] ISO 7040, *Prevailing torque type hexagon regular nuts (with non-metallic insert) — Property classes 5, 8 and 10*
- [13] ISO 7041, *Prevailing torque type hexagon nuts (with non-metallic insert), style 2 — Property classes 9 and 12*
- [14] ISO 7042, *Prevailing torque type all-metal hexagon high nuts — Property classes 5, 8, 10 and 12*
- [15] ISO 7043, *Prevailing torque type hexagon nuts with flange (with non-metallic insert), style 2 — Product grades A and B*
- [16] ISO 7044, *Prevailing torque type all-metal hexagon nuts with flange, style 2 — Product grades A and B*
- [17] ISO 7719, *Prevailing torque type all-metal hexagon regular nuts — Property classes 5, 8 and 10*
- [18] ISO 7720, *Prevailing torque type all-metal hexagon nuts, style 2 — Property class 9*
- [19] ISO 8673, *Hexagon regular nuts (style 1) with metric fine pitch thread — Product grades A and B*
- [20] ISO 8674, *Hexagon high nuts (style 2) with metric fine pitch thread — Product grades A and B*
- [21] ISO 8675, *Hexagon thin nuts chamfered (style 0) with metric fine pitch thread — Product grades A and B*
- [22] ISO 8676, *Hexagon head screws with metric fine pitch thread — Product grades A and B*
- [23] ISO 8765, *Hexagon head bolts with metric fine pitch thread — Product grades A and B*
- [24] ISO 10511, *Prevailing torque type hexagon thin nuts (with non-metallic insert)*
- [25] ISO 10512, *Prevailing torque type hexagon regular nuts (with non-metallic insert) with metric fine pitch thread — Property classes 6, 8 and 10*
- [26] ISO 10513, *Prevailing torque type all-metal hexagon high nuts with metric fine pitch thread — Property classes 8, 10 and 12*
- [27] ISO 10663, *Hexagon nuts with flange, style 2 — Fine pitch thread*

- [28] ISO 12125, *Prevailing torque type hexagon nuts with flange (with non-metallic insert) with metric fine pitch thread, style 2 — Product grades A and B*
- [29] ISO 12126, *Prevailing torque type all-metal hexagon nuts with flange with metric fine pitch thread, style 2 — Product grades A and B*
- [30] ISO 15071, *Hexagon bolts with flange — Small series — Product grade A*
- [31] ISO 15072, *Hexagon bolts with flange with metric fine pitch thread — Small series — Product grade A*
- [32] ISO 21670, *Hexagon weld nuts with flange*

ICS 21.060.20

Price based on 6 pages