

---

---

**Countersunk flat head screws (common  
head style) with type H or type Z cross  
recess — Product grade A —**

Part 1:  
**Steel screws of property class 4.8**

*Vis à métaux à tête fraisée à empreinte cruciforme de type H ou de  
type Z — Grade A —*

*Partie 1: Vis en acier de classe de qualité 4.8*



FINESZ 泛微



**COPYRIGHT PROTECTED DOCUMENT**

© ISO 2011

All rights reserved. Unless otherwise specified, no part of this publication may be reproduced or utilized in any form or by any means, electronic or mechanical, including photocopying and microfilm, without permission in writing from either ISO at the address below or ISO's member body in the country of the requester.

ISO copyright office  
Case postale 56 • CH-1211 Geneva 20  
Tel. + 41 22 749 01 11  
Fax + 41 22 749 09 47  
E-mail [copyright@iso.org](mailto:copyright@iso.org)  
Web [www.iso.org](http://www.iso.org)

Published in Switzerland

## Foreword

ISO (the International Organization for Standardization) is a worldwide federation of national standards bodies (ISO member bodies). The work of preparing International Standards is normally carried out through ISO technical committees. Each member body interested in a subject for which a technical committee has been established has the right to be represented on that committee. International organizations, governmental and non-governmental, in liaison with ISO, also take part in the work. ISO collaborates closely with the International Electrotechnical Commission (IEC) on all matters of electrotechnical standardization.

International Standards are drafted in accordance with the rules given in the ISO/IEC Directives, Part 2.

The main task of technical committees is to prepare International Standards. Draft International Standards adopted by the technical committees are circulated to the member bodies for voting. Publication as an International Standard requires approval by at least 75 % of the member bodies casting a vote.

Attention is drawn to the possibility that some of the elements of this document may be the subject of patent rights. ISO shall not be held responsible for identifying any or all such patent rights.

ISO 7046-1 was prepared by Technical Committee ISO/TC 2, *Fasteners*, Subcommittee SC 11, *Fasteners with metric external thread*.

This second edition cancels and replaces the first edition (ISO 7046-1:1994), of which it constitutes a minor revision.

ISO 7046 consists of the following parts, under the general title *Countersunk flat head screws (common head style) with type H or type Z cross recess — Product grade A*:

- *Part 1: Steel screws of property class 4.8*
- *Part 2: Steel screws of property class 8.8, stainless steel screws and non-ferrous metal screws*



# Countersunk flat head screws (common head style) with type H or type Z cross recess — Product grade A —

## Part 1: Steel screws of property class 4.8

### 1 Scope

This part of ISO 7046 specifies the characteristics of countersunk flat head screws with threads from M1,6 to M10 inclusive, of product grade A and property class 4.8, and with type H or type Z cross recess.

If, in special cases, specifications other than those listed in this part of ISO 7046 are required, they can be selected from existing International Standards, for example ISO 261, ISO 888, ISO 898-1 and ISO 965-2.

### 2 Normative references

The following referenced documents are indispensable for the application of this document. For dated references, only the edition cited applies. For undated references, the latest edition of the referenced document (including any amendments) applies.

ISO 225, *Fasteners — Bolts, screws, studs and nuts — Symbols and descriptions of dimensions*

ISO 261, *ISO general purpose metric screw threads — General plan*

ISO 898-1, *Mechanical properties of fasteners made of carbon steel and alloy steel — Part 1: Bolts, screws and studs with specified property classes — Coarse thread and fine pitch thread*

ISO 965-2, *ISO general purpose metric screw threads — Tolerances — Part 2: Limits of sizes for general purpose external and internal screw threads — Medium quality*

ISO 3269, *Fasteners — Acceptance inspection*

ISO 4042, *Fasteners — Electroplated coatings*

ISO 4757, *Cross recesses for screws*

ISO 4759-1, *Tolerances for fasteners — Part 1: Bolts, screws, studs and nuts — Product grades A, B and C*

ISO 6157-1, *Fasteners — Surface discontinuities — Part 1: Bolts, screws and studs for general requirements*

ISO 8992, *Fasteners — General requirements for bolts, screws, studs and nuts*

### 3 Dimensions

See Figure 1 and Table 1. Symbols and descriptions of dimensions are specified in ISO 225.

The shank diameter is approximately equal to the pitch diameter or equal to the permissible major thread diameter.

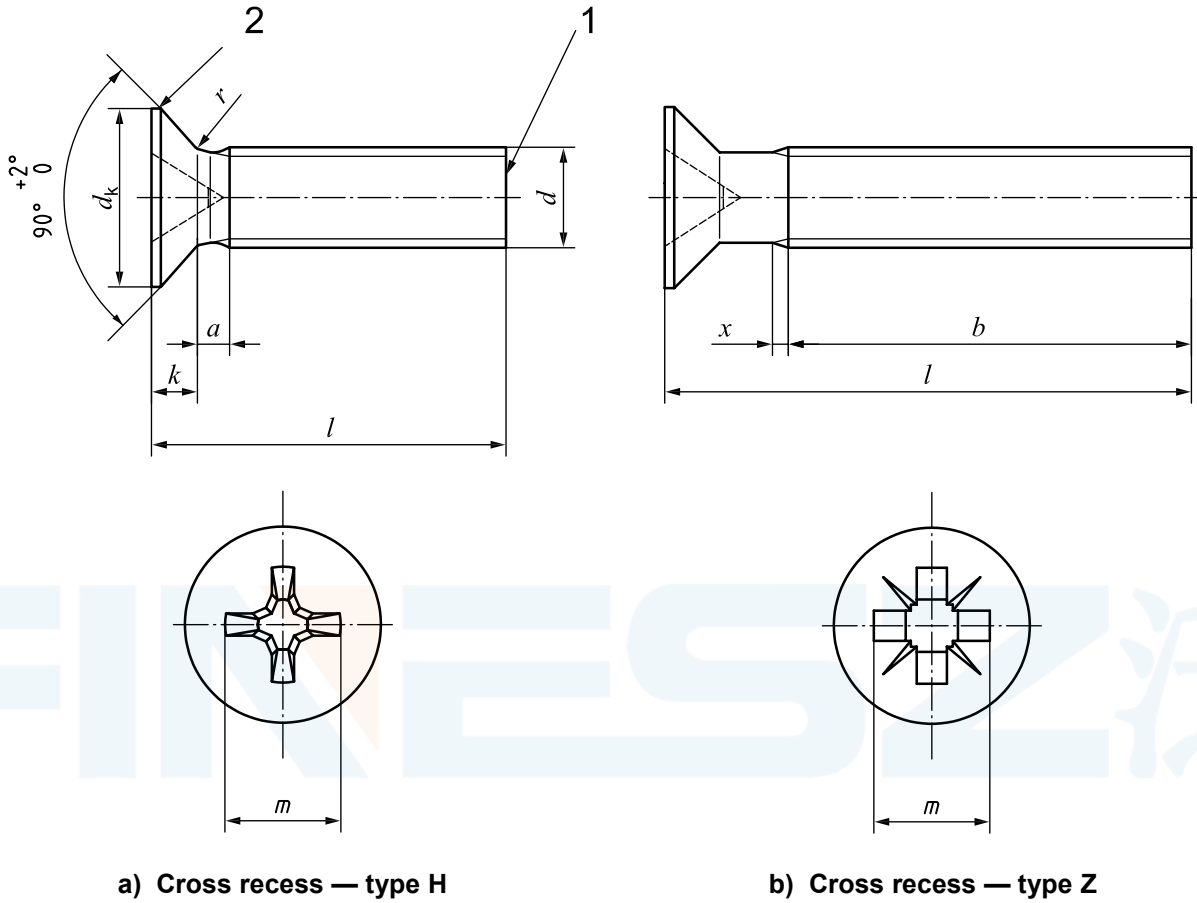

**Key**

- 1 as-rolled end
- 2 edge (rounded or flat)

Figure 1

Table 1 — Dimensions

Dimensions in millimetres

Thread, $d$			M1,6	M2	M2,5	M3	(M3,5) <sup>a</sup>	M4	M5	M6	M8	M10		
$p^b$			0,35	0,4	0,45	0,5	0,6	0,7	0,8	1	1,25	1,5		
$a$	max.		0,7	0,8	0,9	1	1,2	1,4	1,6	2	2,5	3		
$b$	min.		25	25	25	25	38	38	38	38	38	38		
$d_k^c$	Theoretical	max.	3,6	4,4	5,5	6,3	8,2	9,4	10,4	12,6	17,3	20		
	Actual	nom. = max.	3,0	3,8	4,7	5,5	7,30	8,40	9,30	11,30	15,80	18,30		
		min.	2,7	3,5	4,4	5,2	6,94	8,04	8,94	10,87	15,37	17,78		
$k^c$	nom. = max.		1	1,2	1,5	1,65	2,35	2,7	2,7	3,3	4,65	5		
$r$	max.		0,4	0,5	0,6	0,8	0,9	1	1,3	1,5	2	2,5		
$x$	max.		0,9	1	1,1	1,25	1,5	1,75	2	2,5	3,2	3,8		
Cross recess (Series 1, deep <sup>d</sup> )	Recess		no.		0		1		2		3	4		
	Type H	$m$	ref.		1,6	1,9	2,9	3,2	4,4	4,6	5,2	6,8	8,9	10
		Penetration	max.	0,9	1,2	1,8	2,1	2,4	2,6	3,2	3,5	4,6	5,7	
	min.		0,6	0,9	1,4	1,7	1,9	2,1	2,7	3,0	4,0	5,1		
	Type Z	$m$	ref.		1,6	1,9	2,8	3	4,1	4,4	4,9	6,6	8,8	9,8
		Penetration	max.	0,95	1,20	1,73	2,01	2,20	2,51	3,05	3,45	4,60	5,64	
			min.	0,70	0,95	1,48	1,76	1,75	2,06	2,60	3,00	4,15	5,19	
$l^{ae}$			Approximate mass, in kilograms per 1 000 pieces ( $\rho = 7,85 \text{ kg/dm}^3$ ) (for information only)											
nom.	min.	max.												
3	2,8	3,2	0,058	0,101	0,176									
4	3,76	4,24	0,069	0,119	0,206	0,291								
5	4,76	5,24	0,081	0,137	0,236	0,335	0,573	0,825						
6	5,76	6,24	0,093	0,152	0,266	0,379	0,633	0,903	1,24					
8	7,71	8,29	0,116	0,193	0,326	0,467	0,753	1,06	1,48	2,38				
10	9,71	10,29	0,139	0,231	0,386	0,555	0,873	1,22	1,72	2,73	5,68			
12	11,65	12,35	0,162	0,268	0,446	0,643	0,993	1,37	1,96	3,08	6,32	9,54		
(14)	13,65	14,35	0,185	0,306	0,507	0,731	1,11	1,53	2,2	3,43	6,96	10,6		
16	15,65	16,35	0,208	0,343	0,567	0,82	1,23	1,68	2,44	3,78	7,6	11,6		
20	19,58	20,42		0,417	0,687	0,996	1,47	2	2,92	4,48	8,88	13,6		
25	24,58	25,42			0,838	1,22	1,77	2,39	3,52	5,36	10,5	16,1		
30	29,58	30,42				1,44	2,07	2,78	4,12	6,23	12,1	18,7		
35	34,5	35,5					2,37	3,17	4,72	7,11	13,7	21,2		
40	39,5	40,5						3,56	5,32	7,98	15,3	23,7		
45	44,5	45,5							5,92	8,86	16,9	26,2		
50	49,5	50,5							6,52	9,73	18,5	28,8		

Table 1 (continued)

Dimensions in millimetres

Thread, <i>d</i>			M1,6	M2	M2,5	M3	(M3,5) <sup>a</sup>	M4	M5	M6	M8	M10
<i>l</i> <sup>ae</sup>			Approximate mass, in kilograms per 1 000 pieces ( $\rho = 7,85 \text{ kg/dm}^3$ ) (for information only)									
nom.	min.	max.										
<b>(55)</b>	54,05	55,95								10,6	20,1	31,3
<b>60</b>	59,05	60,95								11,5	21,7	33,8
NOTE Preferred lengths are those between the solid, bold, continuous lines.												
<sup>a</sup> Sizes in parentheses should be avoided if possible.												
<sup>b</sup> <i>P</i> is the pitch of the thread.												
<sup>c</sup> See ISO 7721.												
<sup>d</sup> See ISO 7721-2.												
<sup>e</sup> Screws with nominal lengths above the bold, discontinuous line are threaded up to the head; $b = l - (k + a)$ .												

#### 4 Specifications and reference International Standards

See Table 2.

Table 2 — Specifications and reference International Standards

<b>Material</b>		Steel
<b>General requirements</b>	International Standard	ISO 8992
<b>Thread</b>	Tolerance class	6g
	International Standard	ISO 261, ISO 965-2
<b>Mechanical property</b>	Property class	4.8
	International Standard	ISO 898-1
<b>Tolerance</b>	Product grade	A
	International Standard	ISO 4759-1
<b>Cross recess</b>	International Standard	ISO 4757
<b>Finish — Coating</b>		As processed
		Requirements for electroplating are specified in ISO 4042. Additional requirements or other finishes or coatings shall be agreed between the supplier and the purchaser.
<b>Surface integrity</b>		Limits for surface discontinuities are specified in ISO 6157-1.
<b>Acceptability</b>		Acceptance inspection is specified in ISO 3269.

#### 5 Designation

EXAMPLE A cross-recessed countersunk flat head screw with thread M5, nominal length  $l = 20 \text{ mm}$ , property class 4.8 and cross recess type Z is designated as follows:

**Countersunk flat head screw ISO 7046-1 - M5 × 20 - 4.8 - Z**



## Bibliography

- [1] ISO 888, *Bolts, screws and studs — Nominal lengths, and thread lengths for general purpose bolts*
- [2] ISO 7721, *Countersunk head screws — Head configuration and gauging*
- [3] ISO 7721-2, *Countersunk flat head screws — Part 2: Penetration depth of cross recesses*

FINESZ 泛微